

ANDERSEN

A2

Installer manual

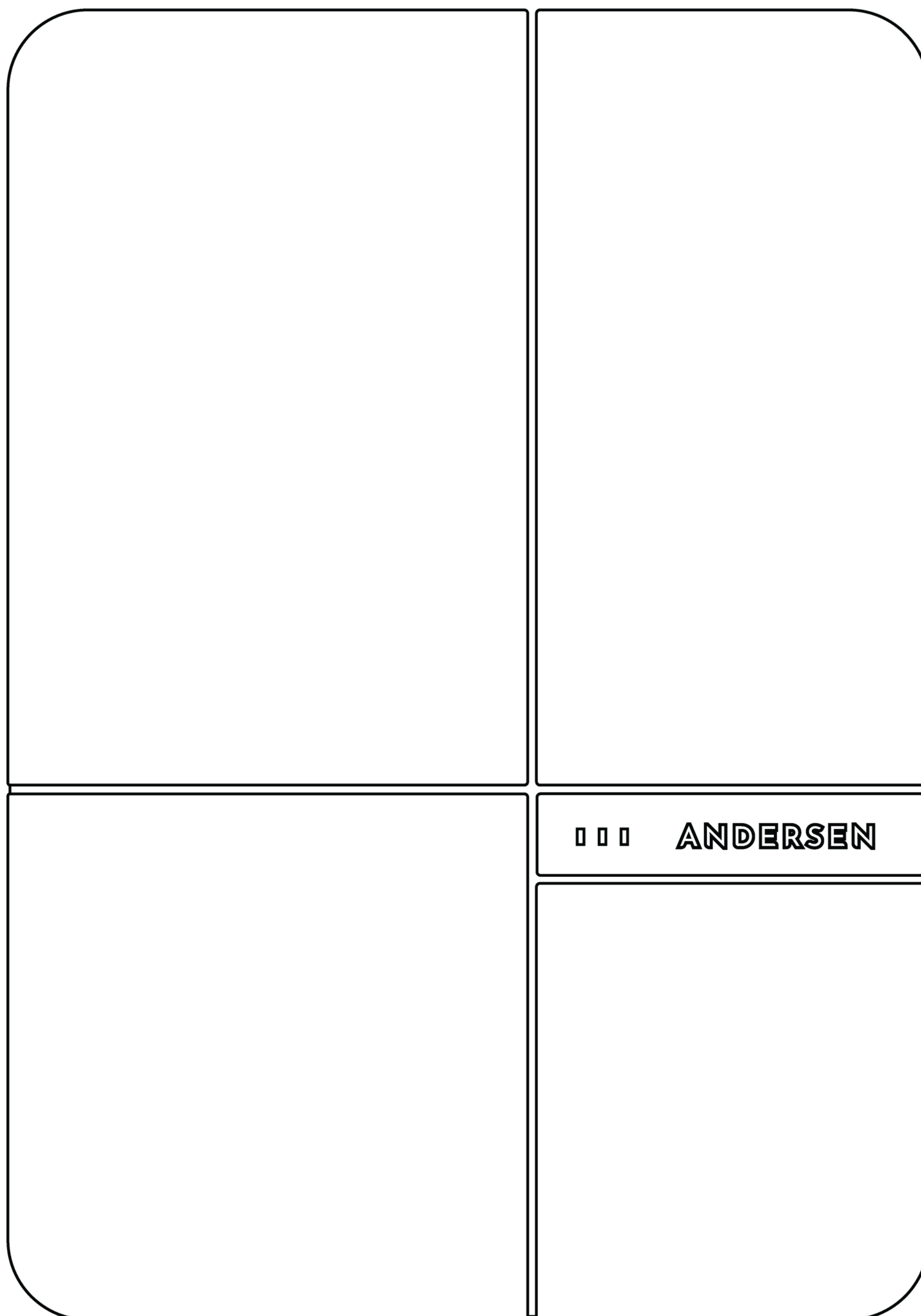

www.andersen-ev.com

Revision 2.4

ANDERSEN DISCLAIMER

The Andersen A2 should only be installed by an electrician with the appropriate knowledge and qualifications. The installation must comply with the current editions of the **IET Code of Practice for Electric Vehicle Charging Equipment installation** and **IET BS 7671 Requirements for Electrical Installations**. Failure to do so could result in injury or death.

It is the responsibility of the installer and/or designer to determine the correct cabling and protective devices where external influences could have an effect on inbuilt protection.

It is also the responsibility of the installer to apply or notify the relevant DNO with the installation details of the charge point and property in accordance with ENA guidance.

Opening of containment should only be carried out when the supply is isolated from the mains. The undertaking of any live testing should only be carried out by a person or persons qualified to do so.

The installation instructions should be followed closely to ensure correct installation and commissioning. Failure to follow these instructions could result in damage to the Andersen Charge point, existing installation or supplier's equipment,

During and on completion of the installation, it shall be inspected, tested and certified to verify that it complies with the current electrical regulations and standards as applicable.

Before the Andersen A2 is put into service, we as the manufacturer require the installer to simulate a charge with a recognised EVSE adaptor and multifunction tester to prove operation and functionality. Use of this equipment should only be undertaken by someone who has an understanding of its functions and has the experience and knowledge to do so.

ANDERSEN A2

Needed

2mm & 3mm
allen keys

Philips head Screwdriver (cross head)



SETUP MULTI FUNCTION OPERATION



Reset RCM (Two button presses)



Enter Network setup mode (Three button presses)



Exit Network setup mode (One button presses)



Enter unit reset mode (Five button presses) + Exist Timeout 30 secs

Muli function button located at the bottom left, inside the cable slot.

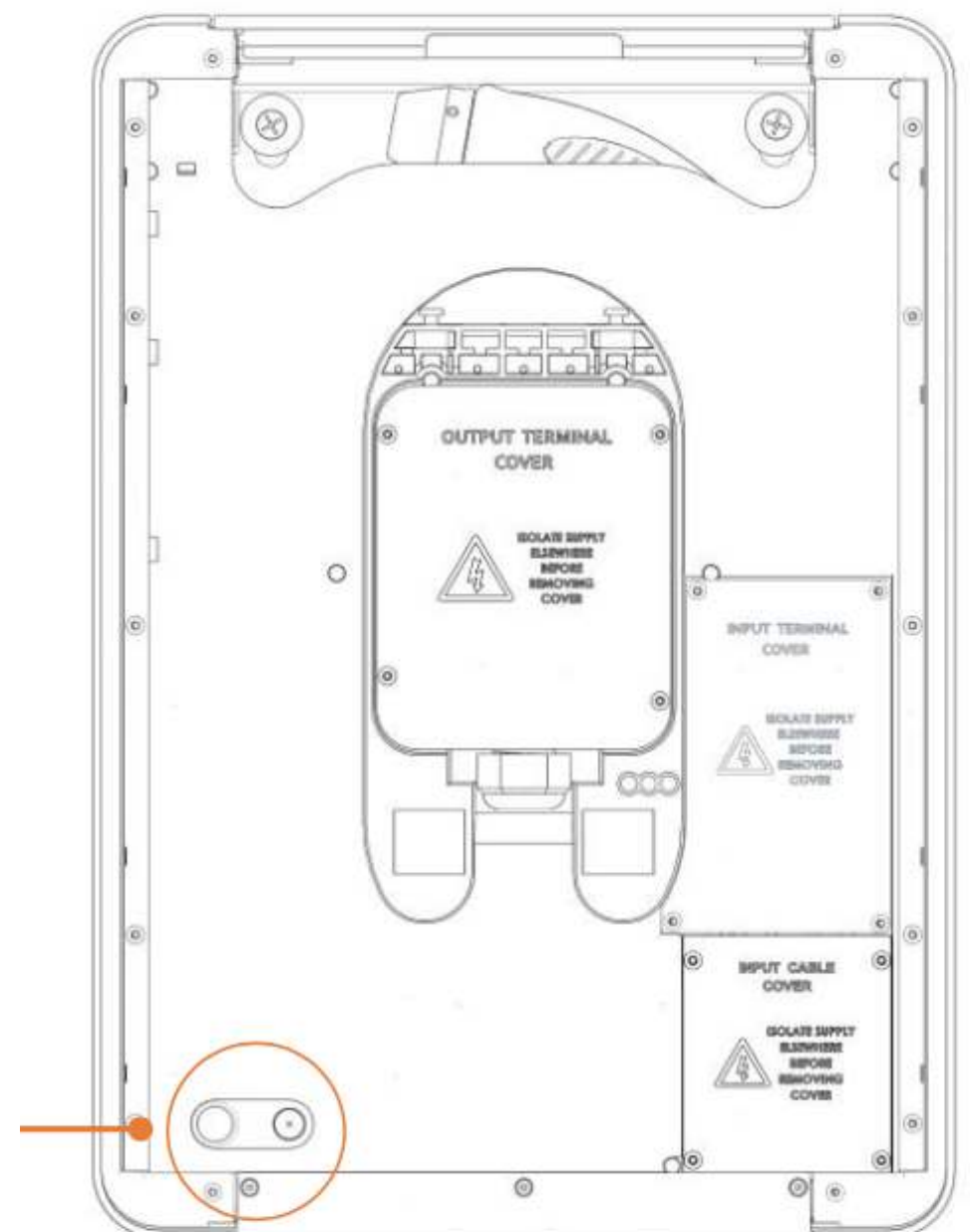

OPERATION LED STATUS

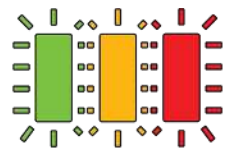

System powering up. Red, Amber, Green LED flash together twice a second



Standby State (solid green)

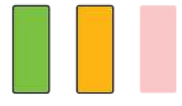

Vehicle connected state (solid green & solid amber)



Vehicle charging state (solid amber)



Charge point locked or awaiting scheduled charge (solid green & solid red)

ERROR & UPDATE LED STATUS

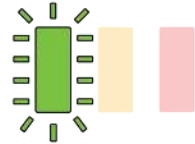

Disconnected from network/cloud (green LED flash every 5 seconds)

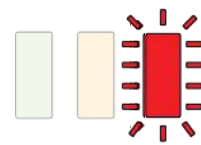

RCM or charge error (flash red every second)

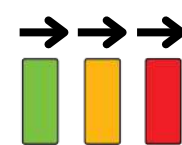

Firmware upgrade (sequence of green, amber, red for duration of upgrade)

SETUP LED STATUS

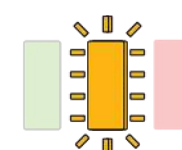

Wifi Setup (Amber LED flash once per second)



Reset warning. (Red, Amber, Green LED flash 4 times per second.)



CT Clamp disconnected (Amber and Red LED flashing)

Step 1: Fix A2 unit to the wall

 x2
6mm penny washer

 x2
6mm washer

The mounting hardware (screws, wall plugs etc) must be selected to be appropriate for the specific structure of the mounting wall.

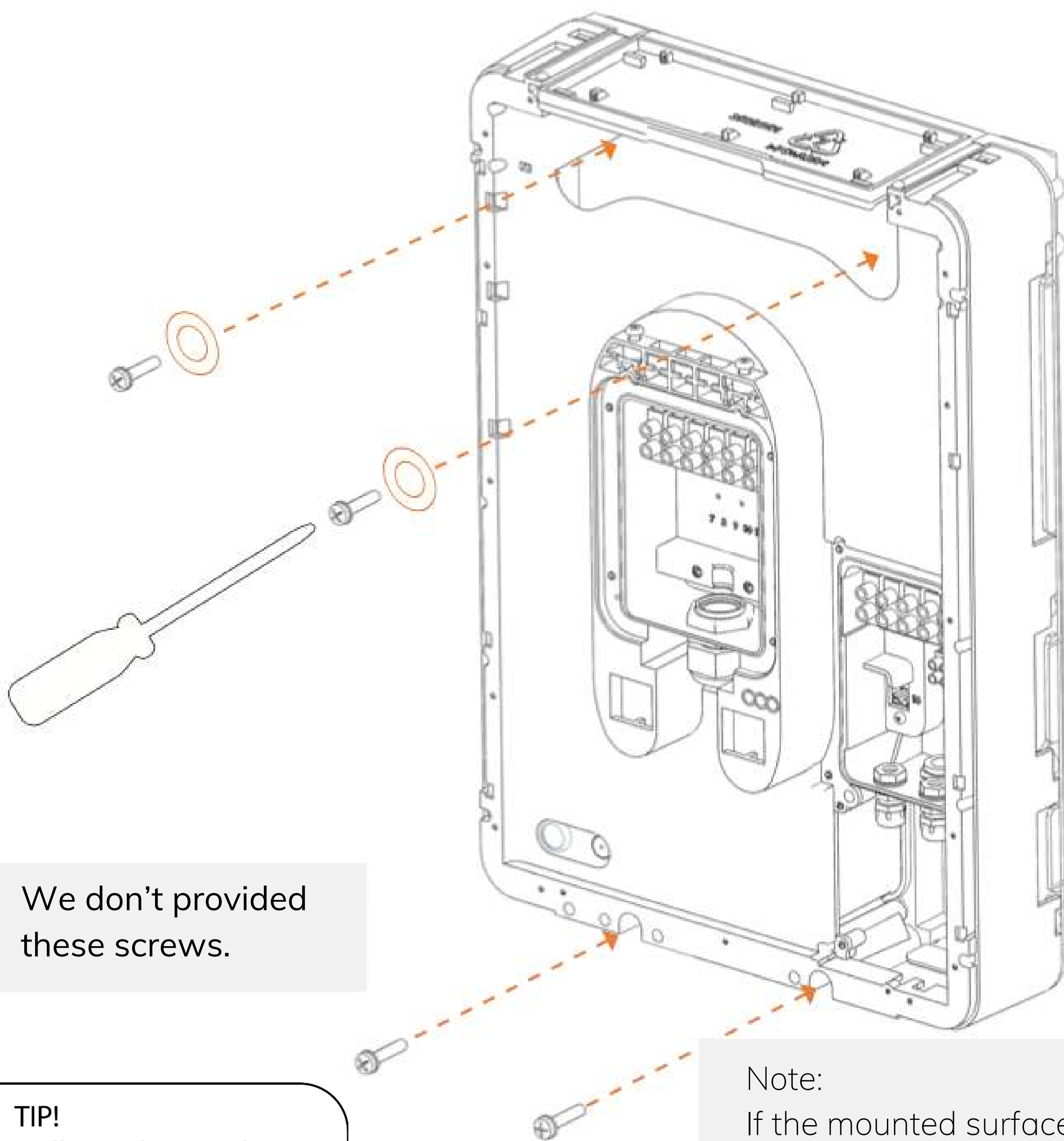

We don't provided these screws.

TIP!
Drill template on the bottom of the cardboard packaging of the unit.

Note:
If the mounted surface is uneven, use spacers to ensure the unit core is sitting flush to the wall.

Step 2: Prepare A2 core for supply cable entry

Show the Inspector

Default cable entry is from the rear See Fig: 1

Note:
This can be done when on wall

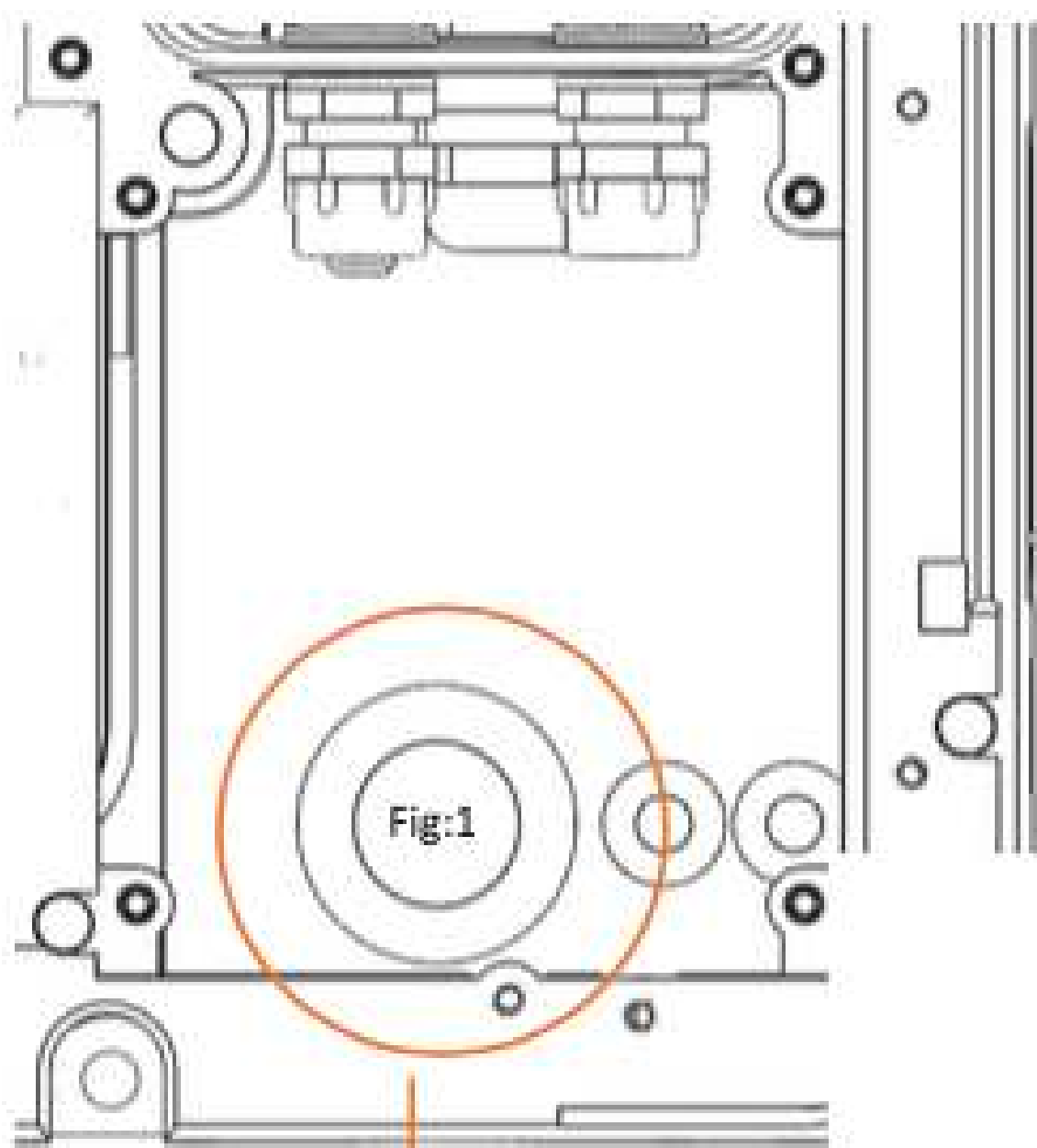

Fig 1

Bottom entry drill out cable entry section with 20 25mm hole saw, see Fig :2
Use rubber grommet from the rear cable entry hole

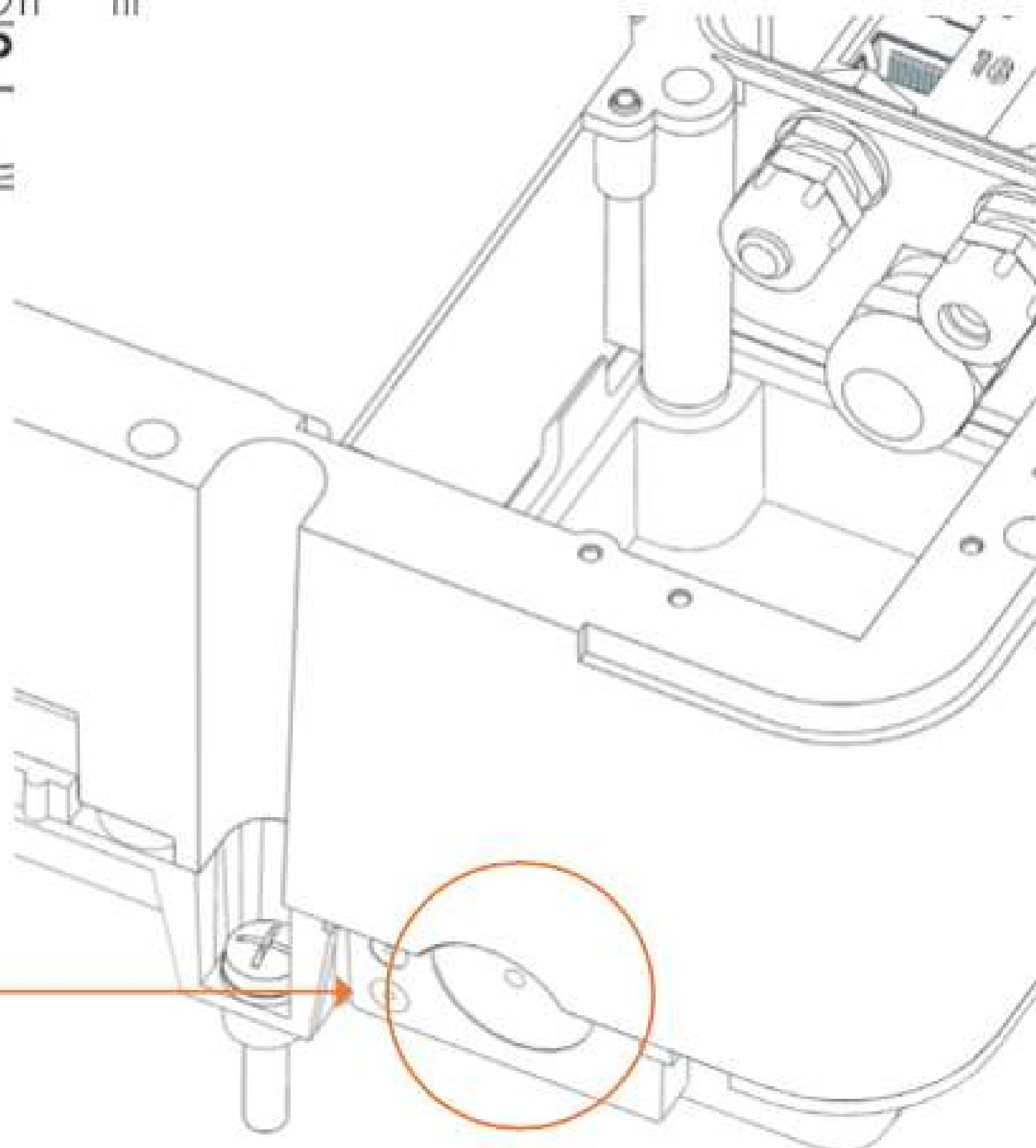
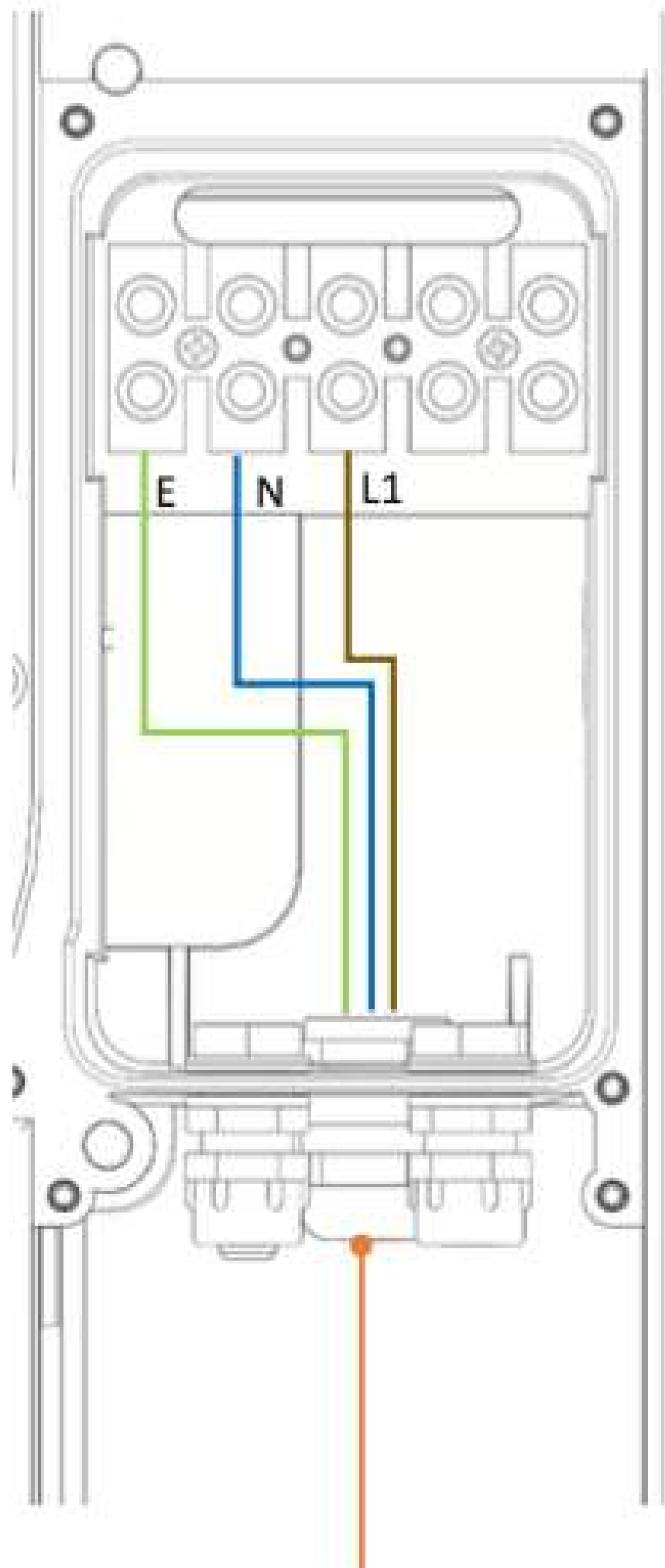

Fig 1

Step 3: Terminate supply power cable

Single Phase installation



Incoming single phase supply

Three Phase installation

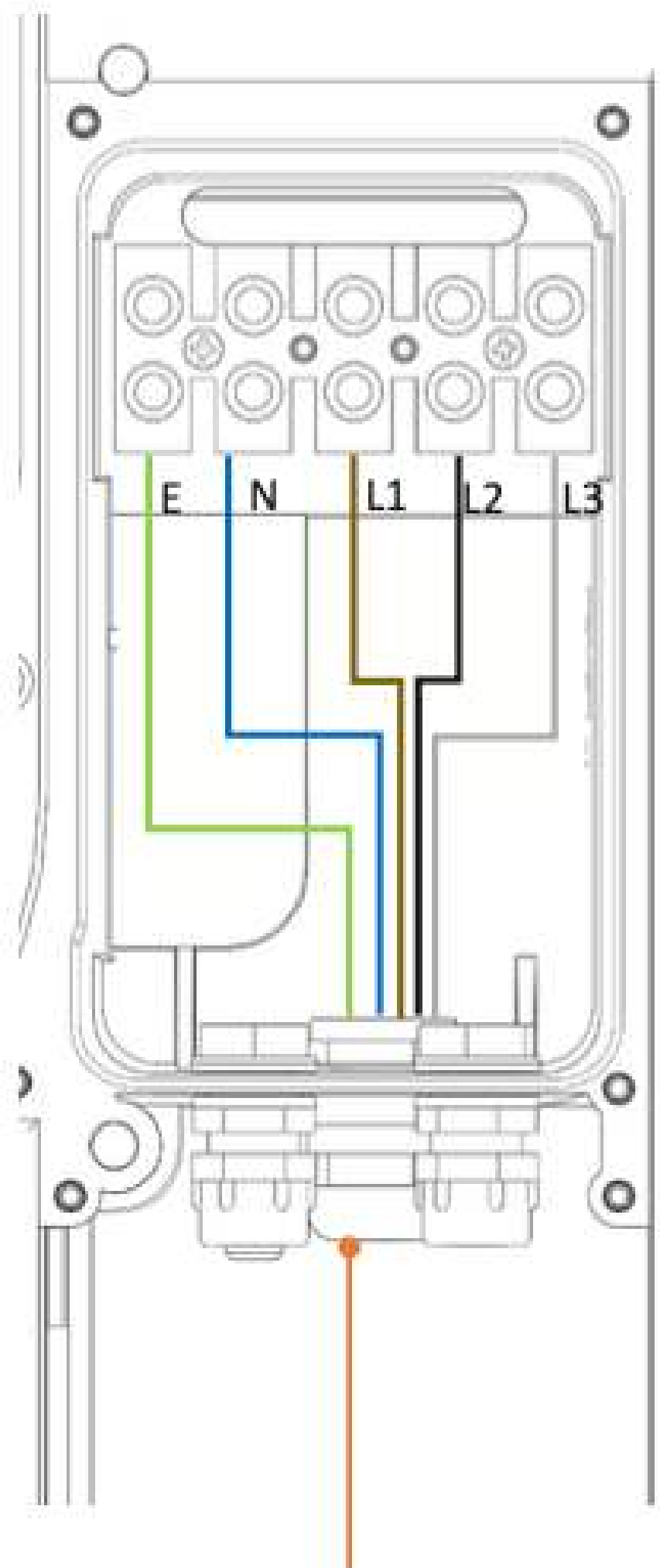

Incoming three phase supply



Torque setting must be 1nM. Check both sides of connector block.

TIP: Recommended supply cable type is CAT5e/6 EV Cable.

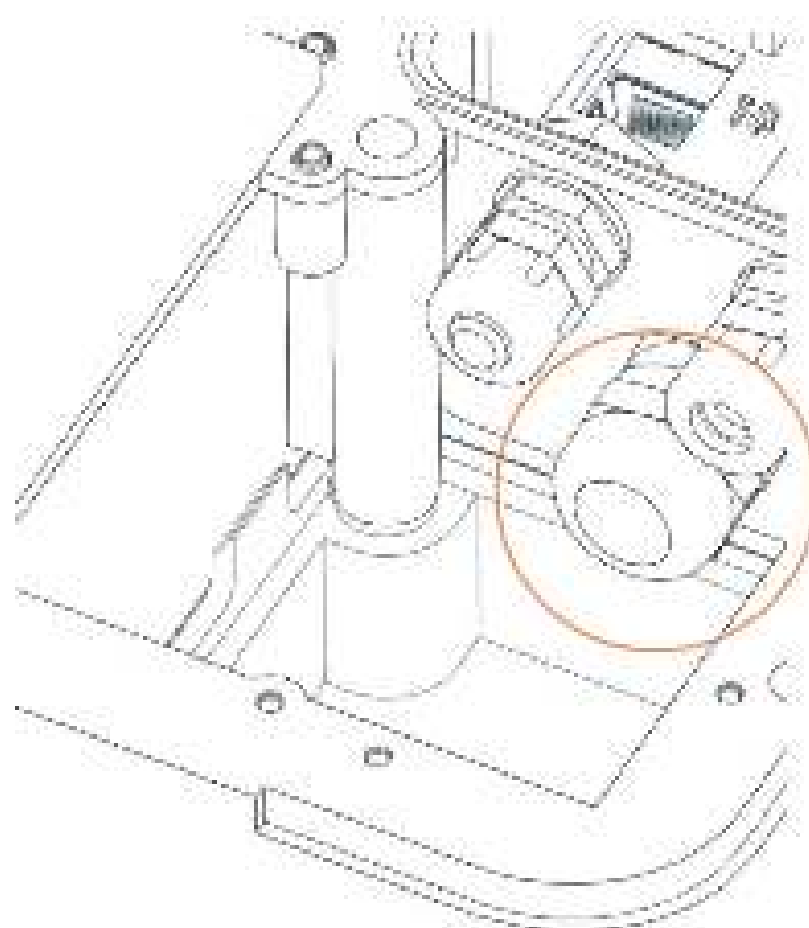

Important. Make sure the gland is tightened after cable installation

Step 4: Terminate sensor cables

Solar Advanced CT
sensor cable*
Optional

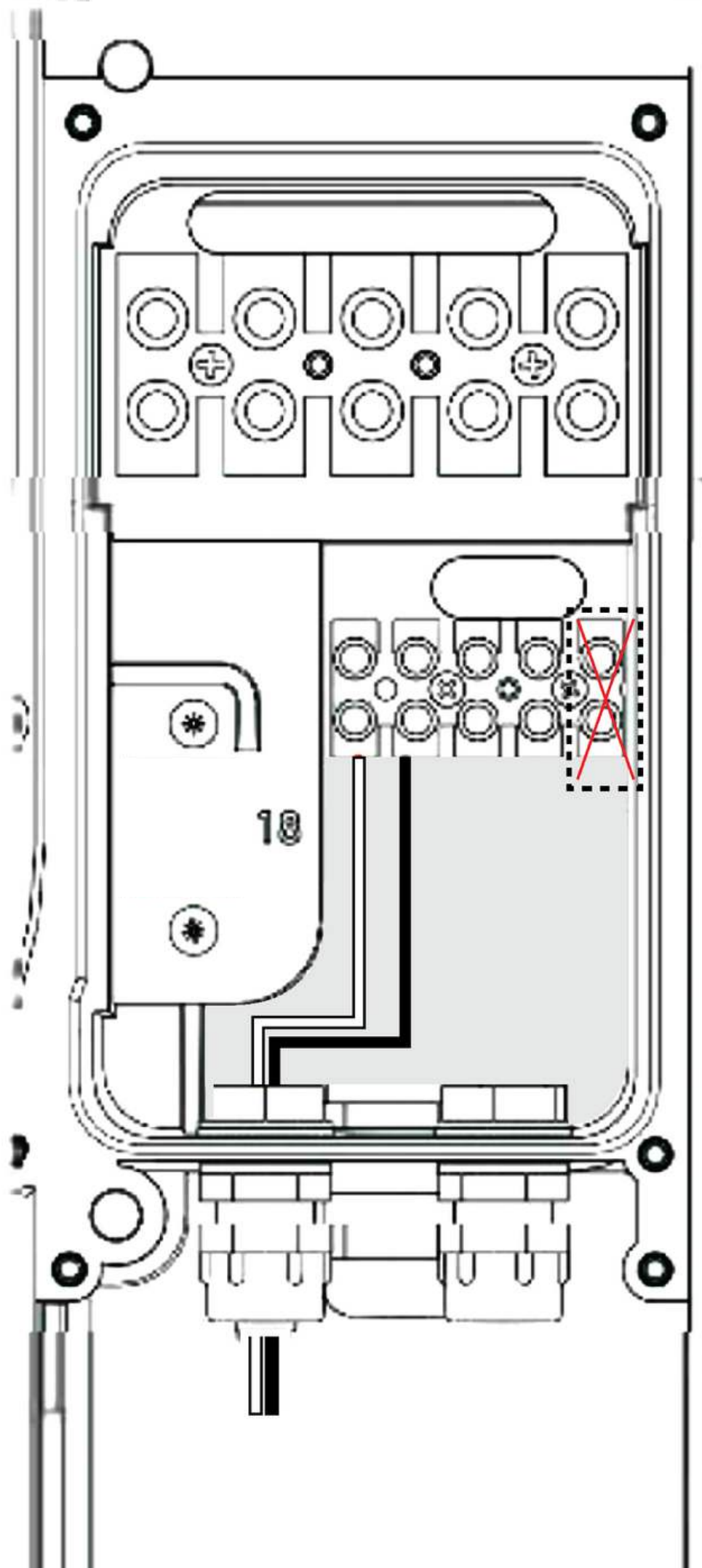

Solar Advanced CT

Note: Fit CT clamp to
PV inverter supply.
Orientation can be
determined during
testing.

Recommended Cable:
Shielded twisted
pair e.g. CAT5e/CAT6

Solar Basic/Adaptive
Fuse CT sensor cable*
Optional

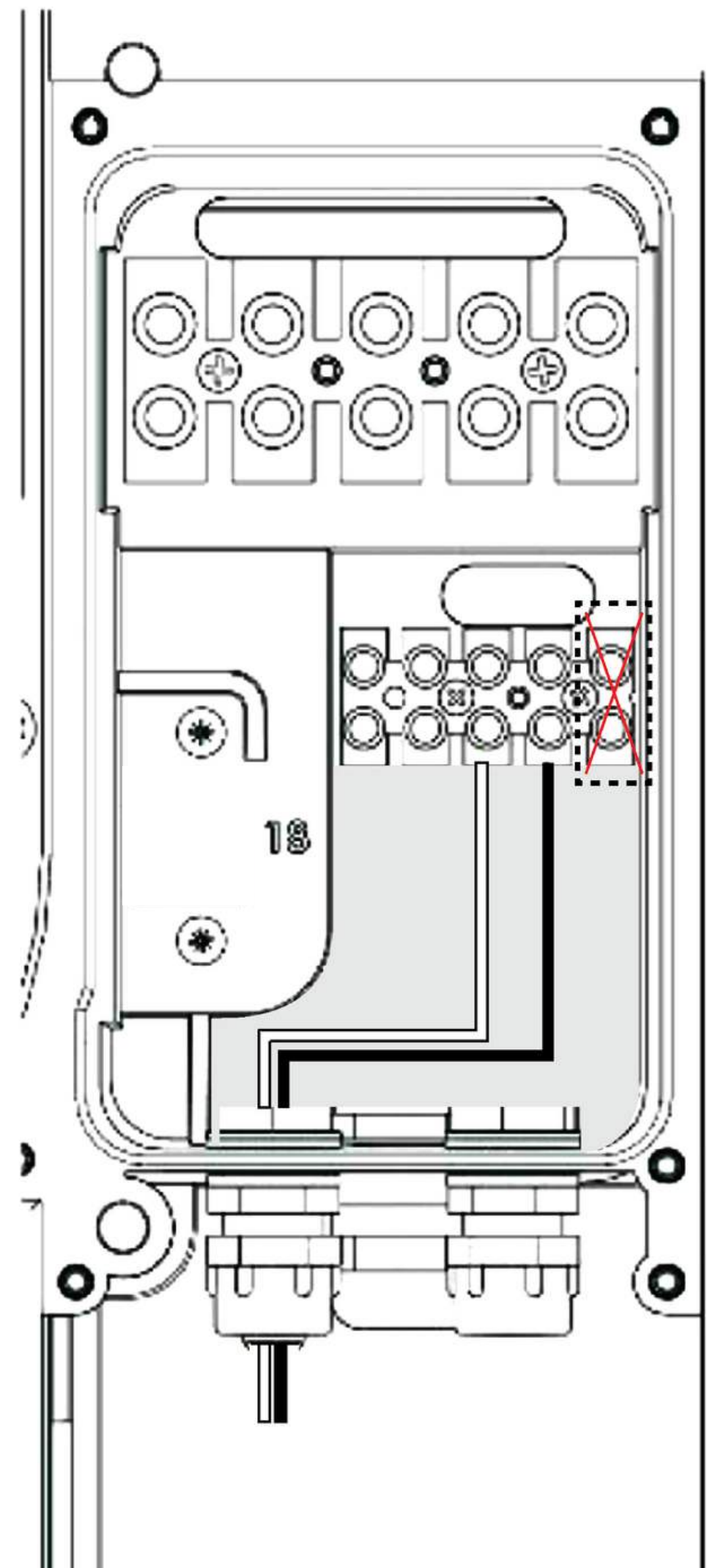

Solar Basic/Adaptive CT

Note: Fit CT clamp
to incoming supply.
Orientation can be
determined during
testing. CT orientation can
be confirmed in
dashboard using a load
reference i.e. kettle 3Kw

Recommended Cable:
Shielded twisted
pair e.g. CAT5e/CAT6

Step 5: Terminate vehicle side charge cable



SINGLE PHASE CABLE

THREE PHASE CABLE

Torque setting must be 1nM. Check both sides of connector block.

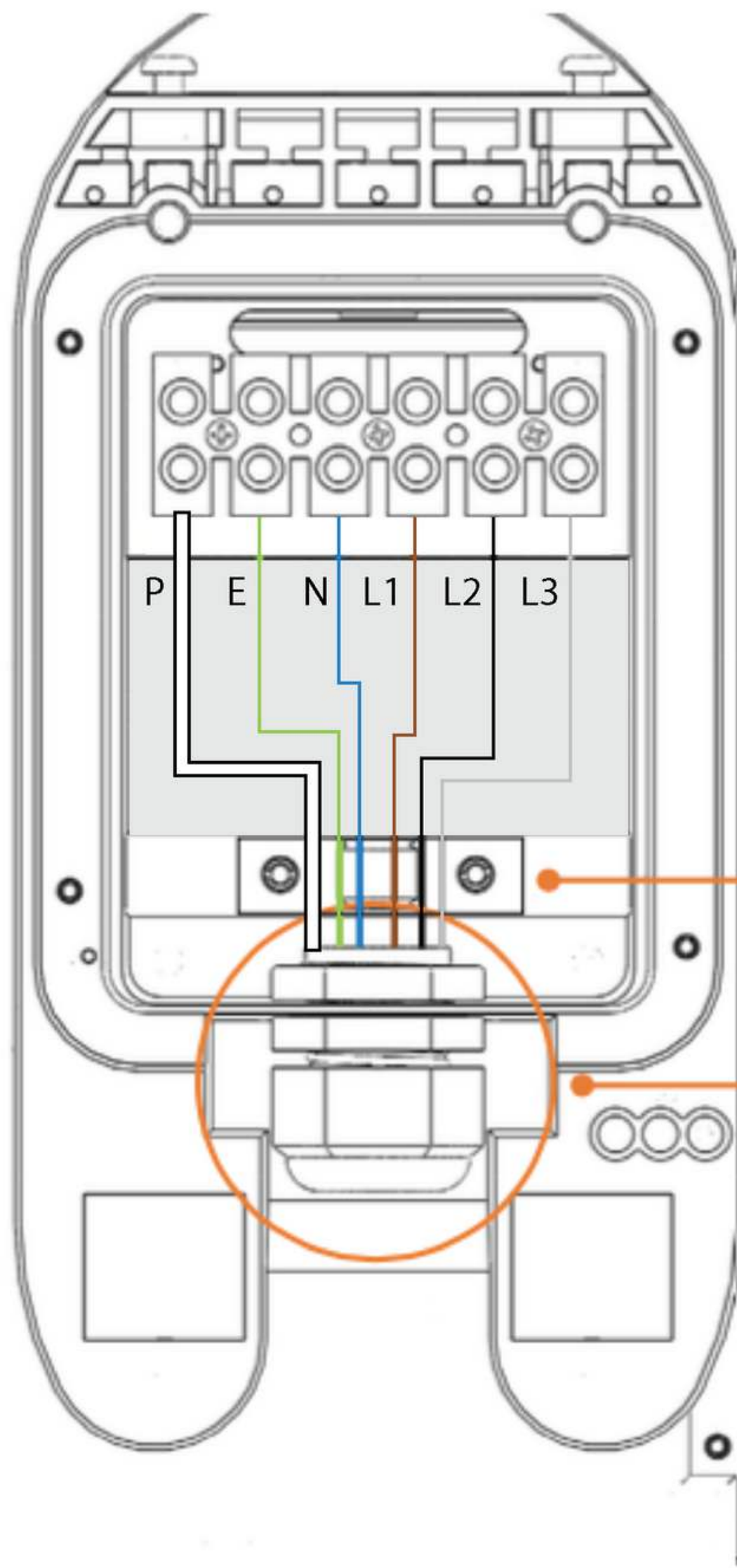
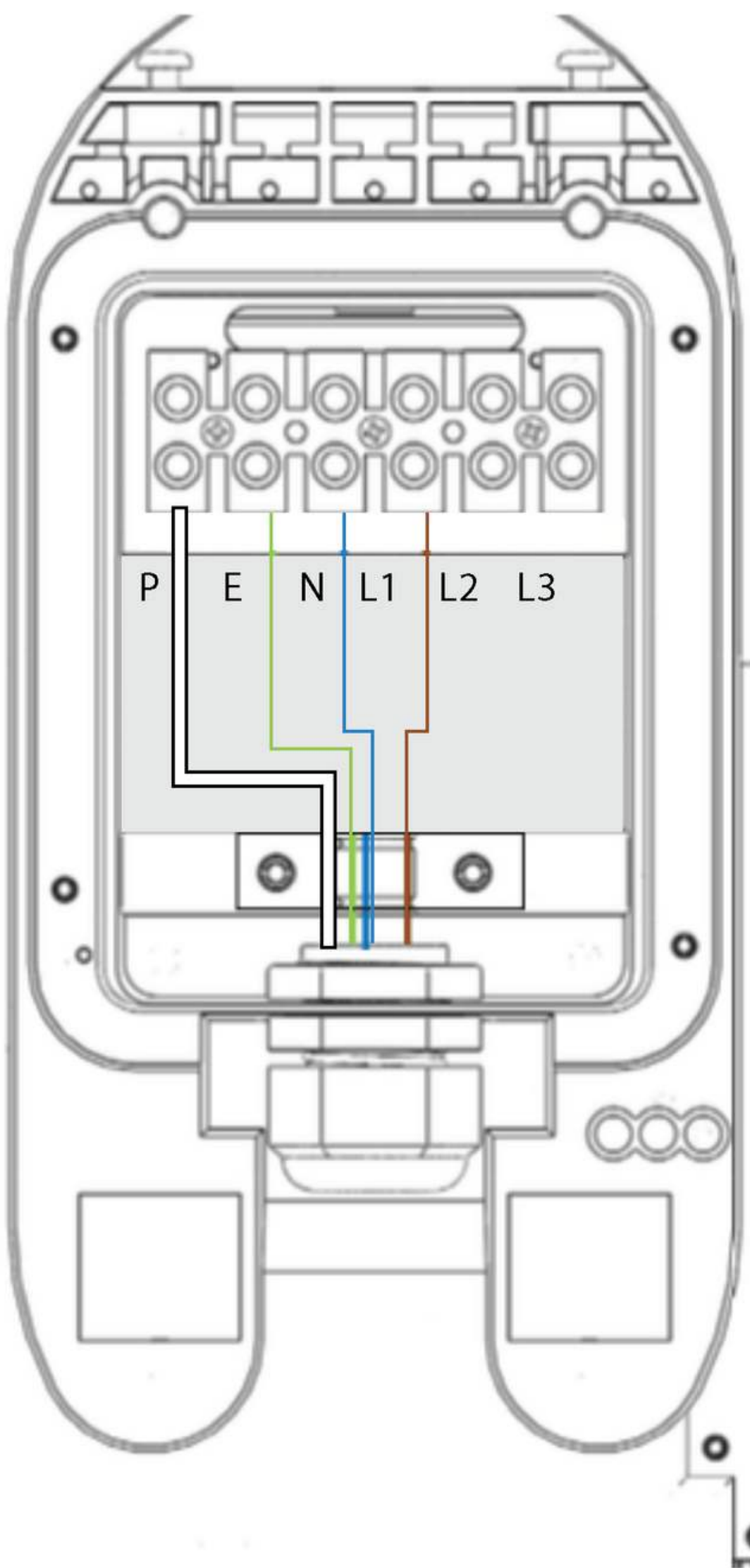

Important. Ensure cable stress relief clamp is correctly tightened



Important. Make sure the gland is tightend after cable installation!

Please note: Orange cable is not used

Step 6: Fit weather project covers

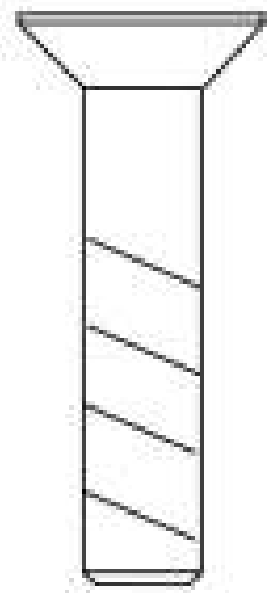

x12
M3 x 16mm long
countersunk screw
steel

Torque setting must be
0.7nM

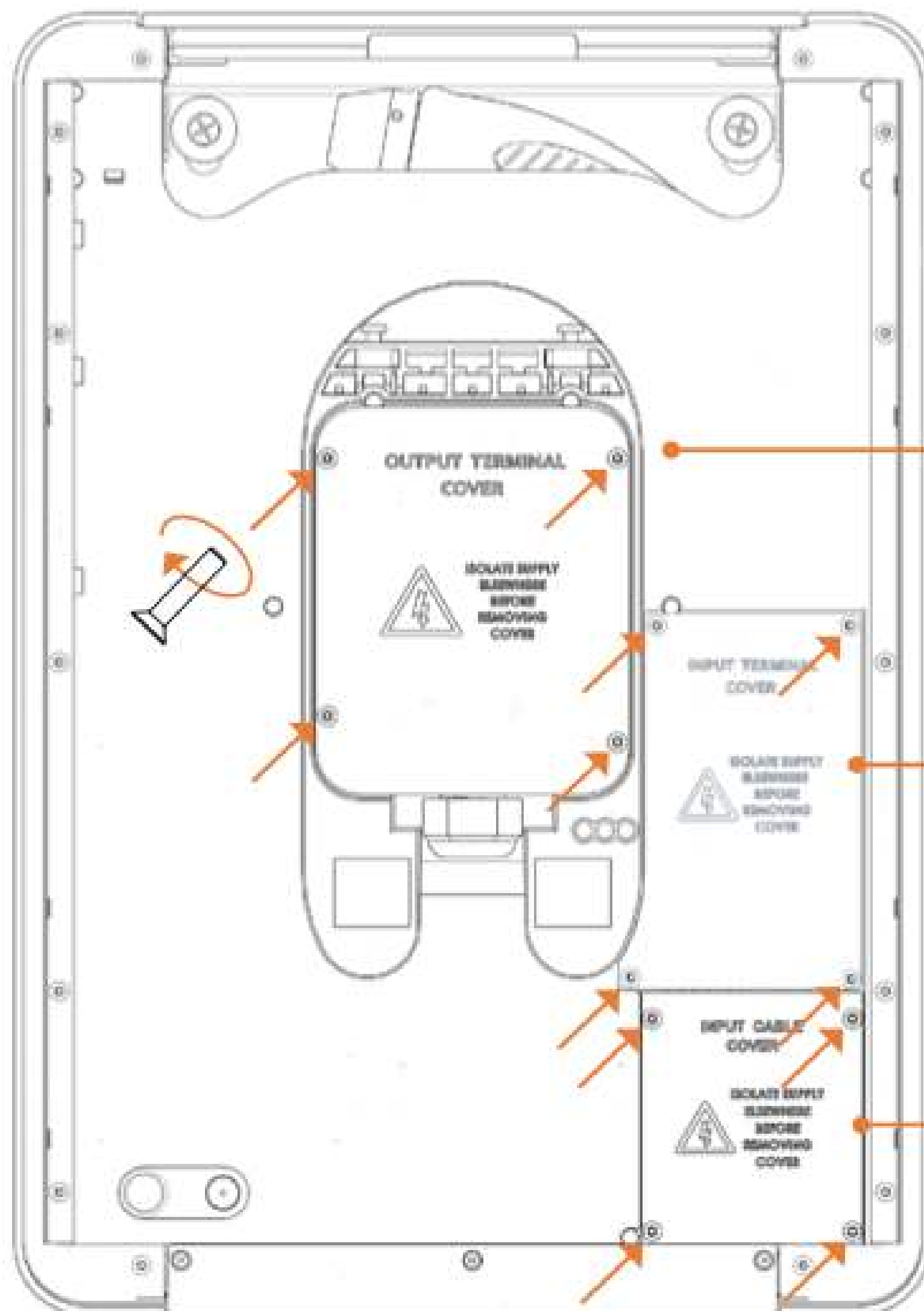

A: Fit output terminal cover. Ensure seals are correctly positioned and fixing screws correctly torqued to 0.7nM

B: Fit input terminal cover. Ensure seals are correctly positioned and fixing screws correctly torqued to 0.7nM

C: Fit input supply cover. Ensure seals are correctly positioned and fixing screws correctly torqued to 0.7nM

Step 7: Fit side panels

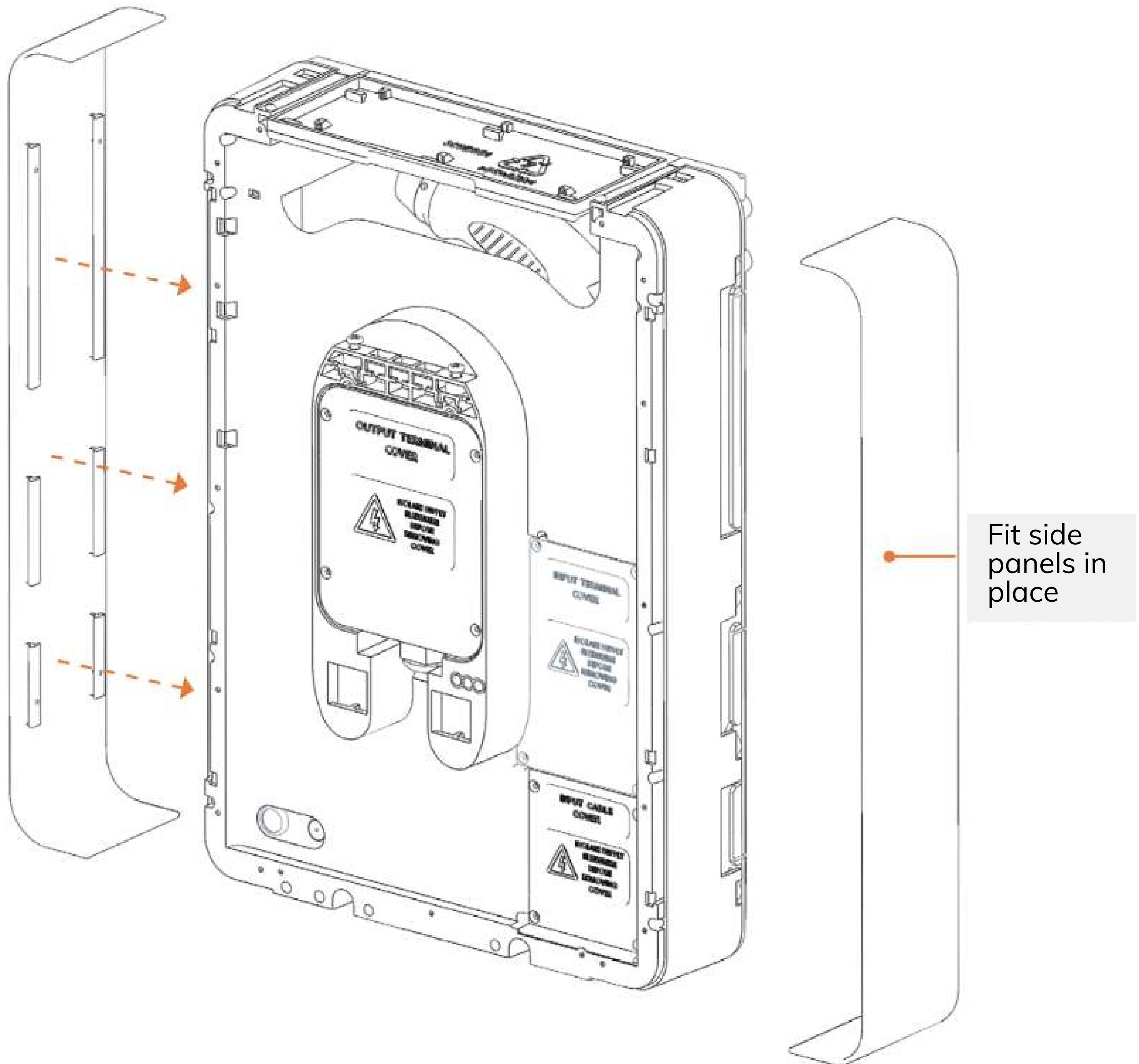

TIPS: Once side panels are located in the slots apply pressure on the top and outwards. Tighten the holding screws on unit brushes to clamp the side panel in.

Please remember the unit must be mounted as flush & flat against the wall as possible.

Step 8: Fit cable brushes

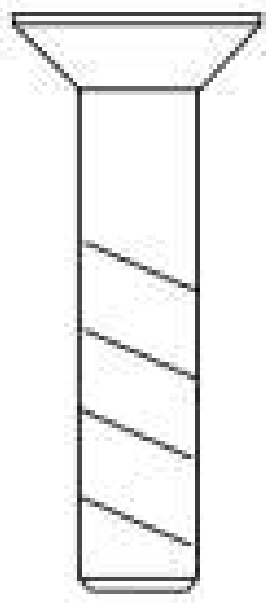

x14
M3 x 16mm long
screw

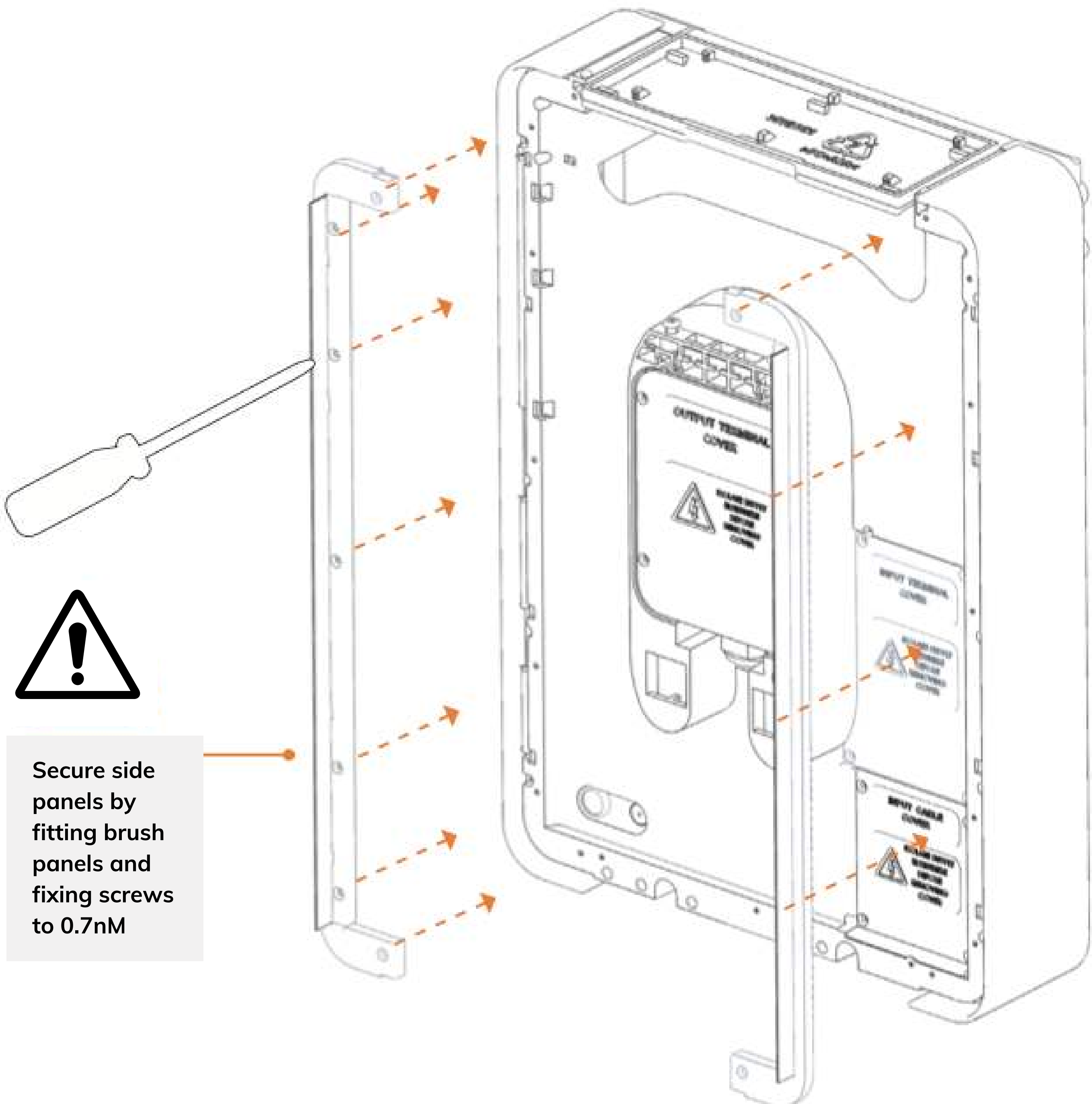

Secure side
panels by
fitting brush
panels and
fixing screws
to 0.7nM

Step 9: Fit lid panel

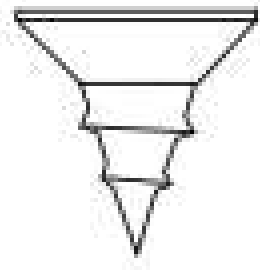

x4
M5 x 8mm counter sunk screw

A: Install lid panel into the lid core.

TIP: Position the lid evenly between the side panels which have already been fitted. Squeeze together the lid and mounting to clip in.

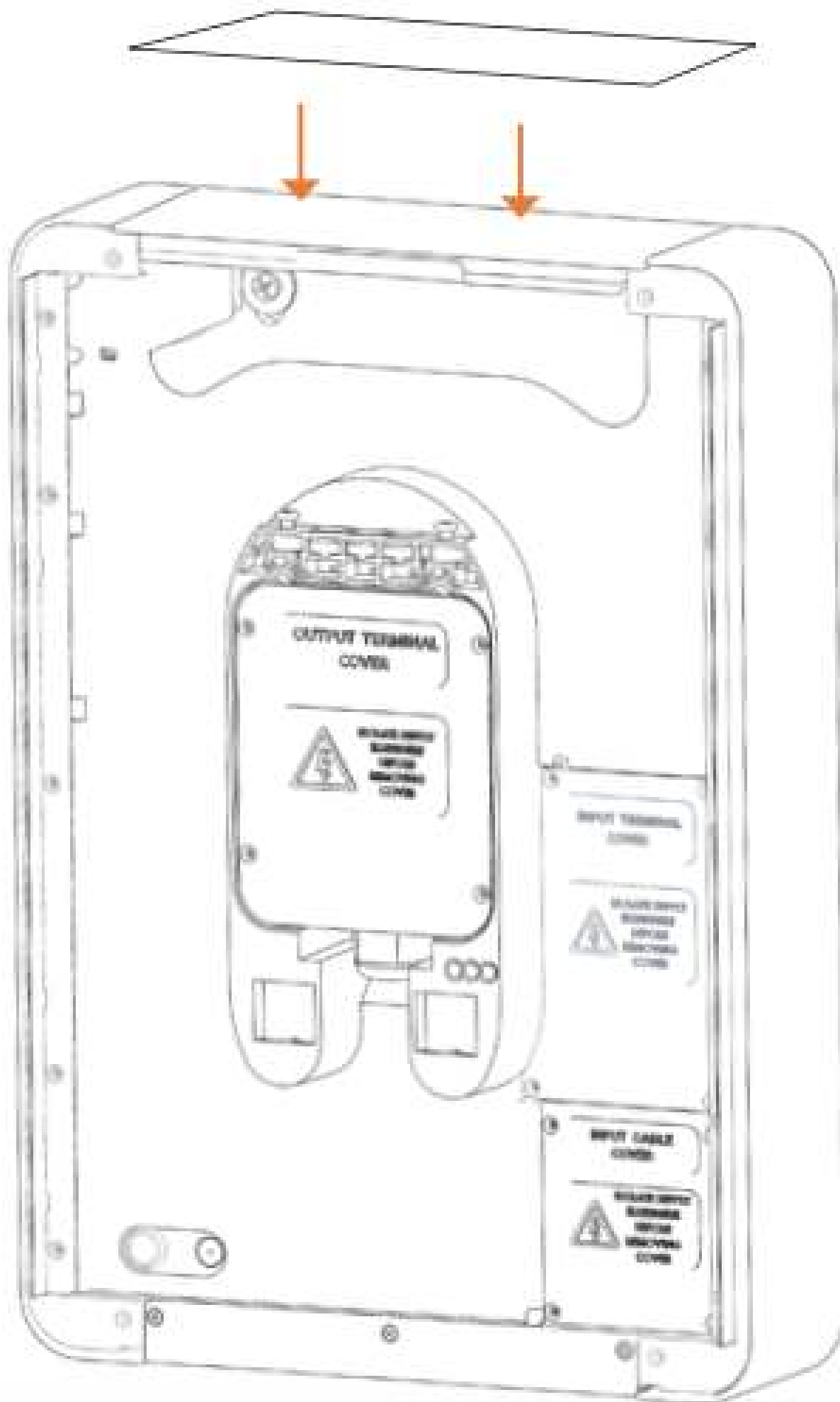

B: Insert and tighten lid fixing screws

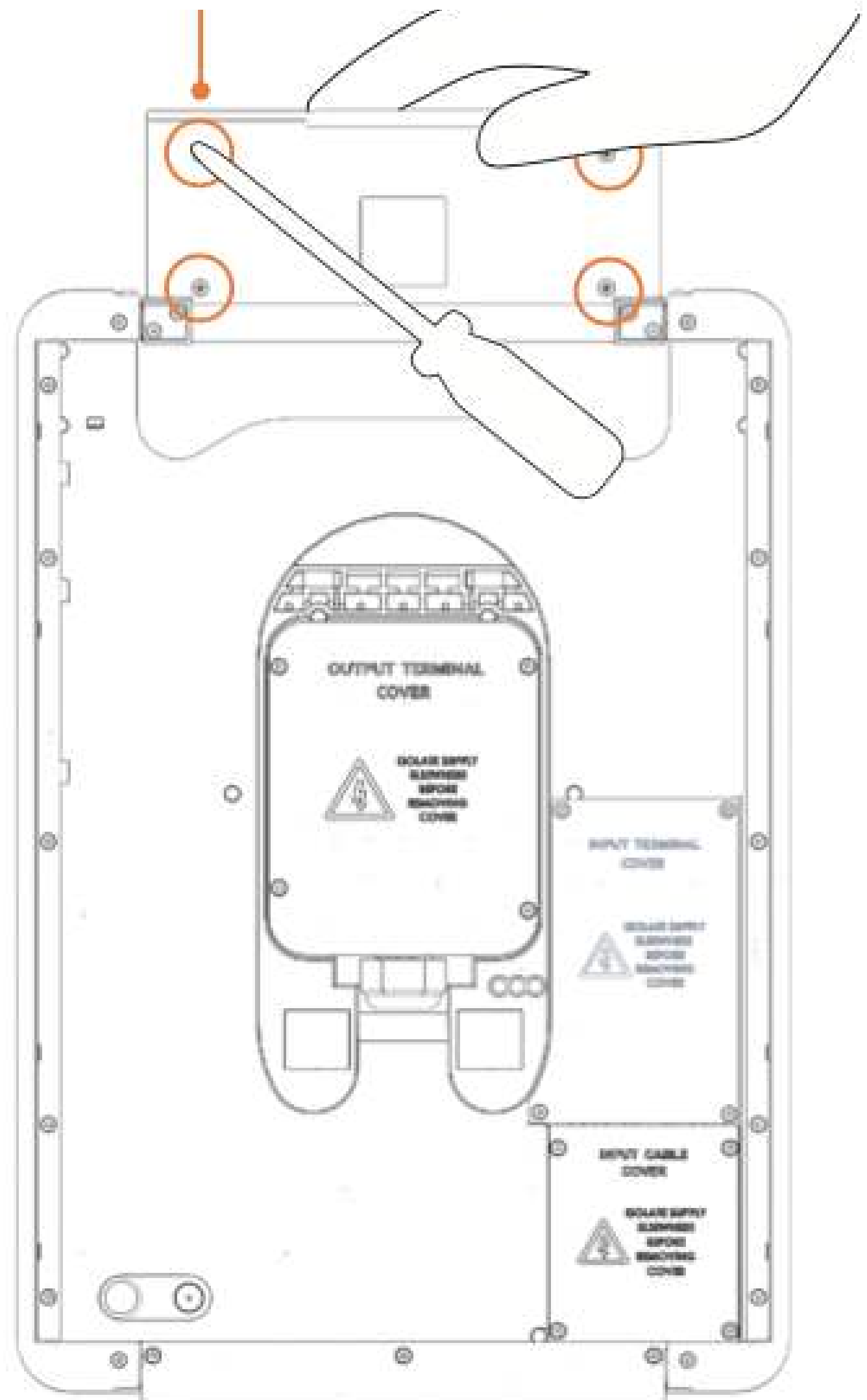

TIP: Grip lid tightly whilst tightening locating screws, to make sure lid does not roll to the right.

Step 10: Fit bottom panel

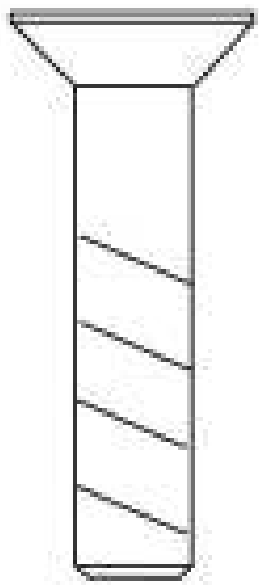

x3
M3 x 16mm long screw

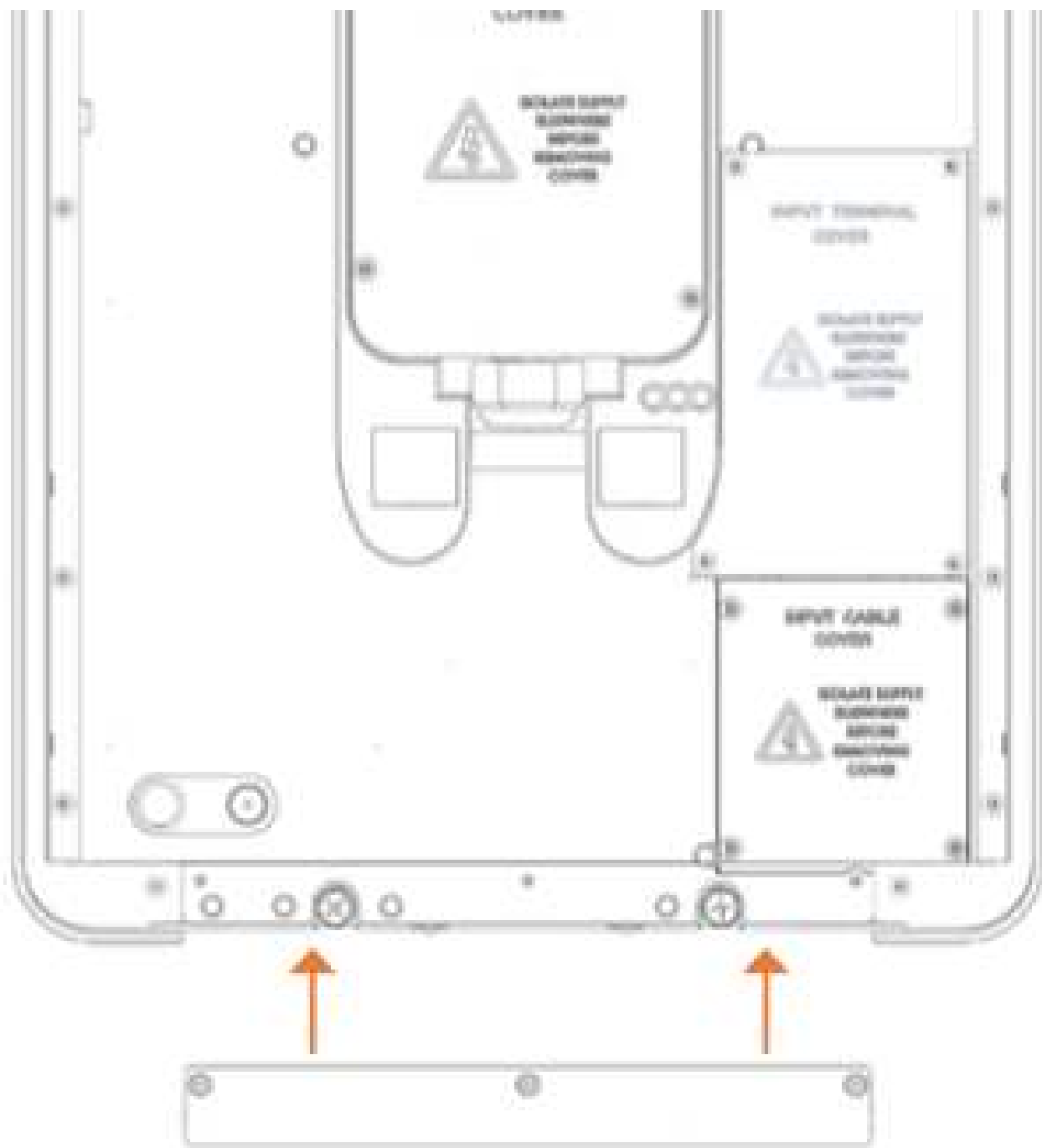

A: Fit bottom cover

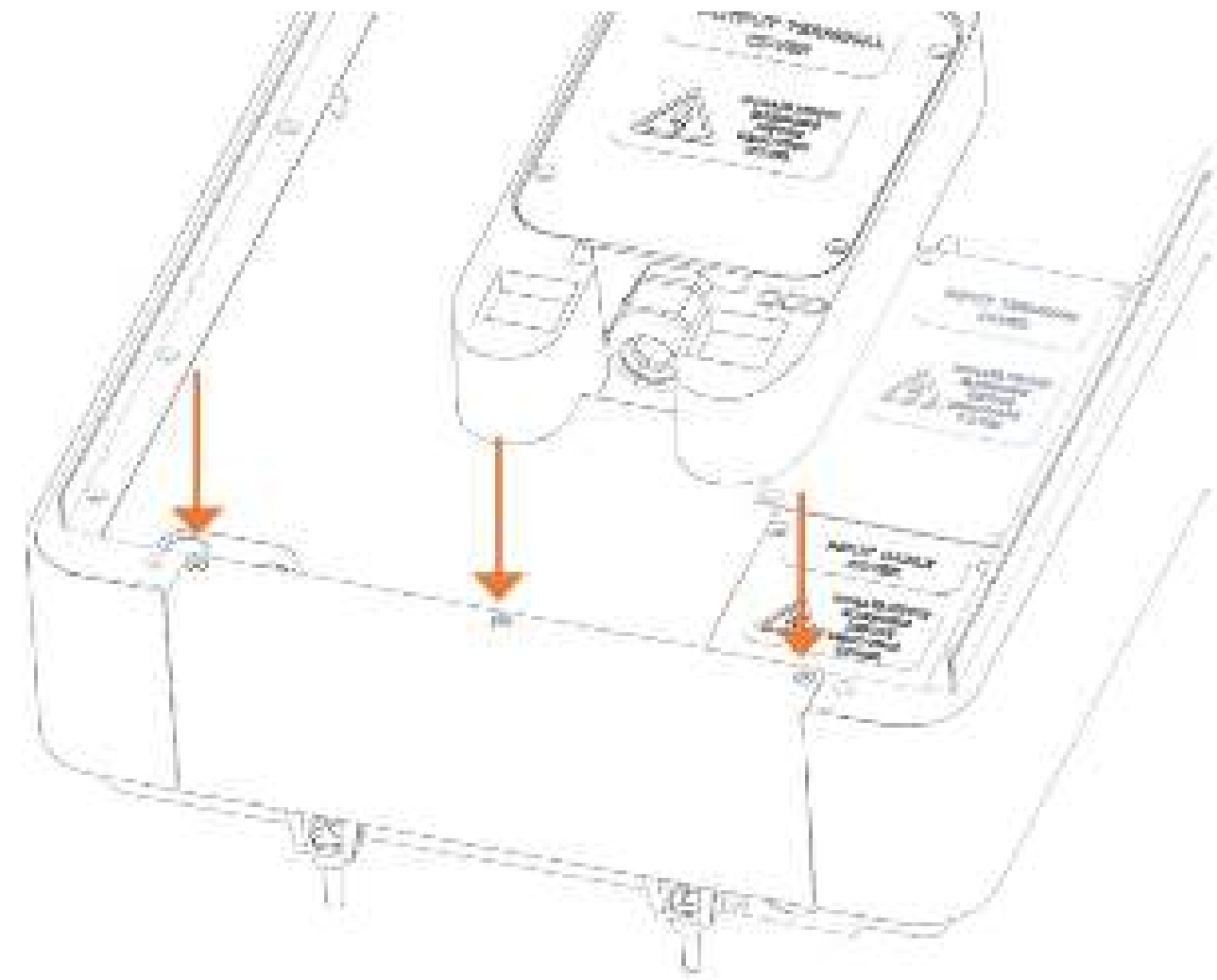

B: Tighten screws
to 0.7nM

Step 11: Fit front panel

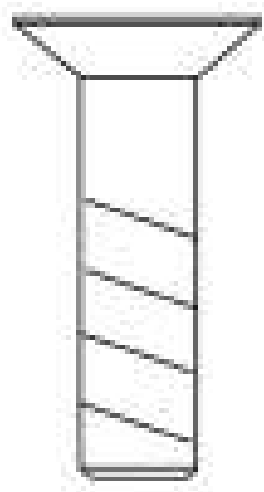

x2
M5 x 12mm long screw

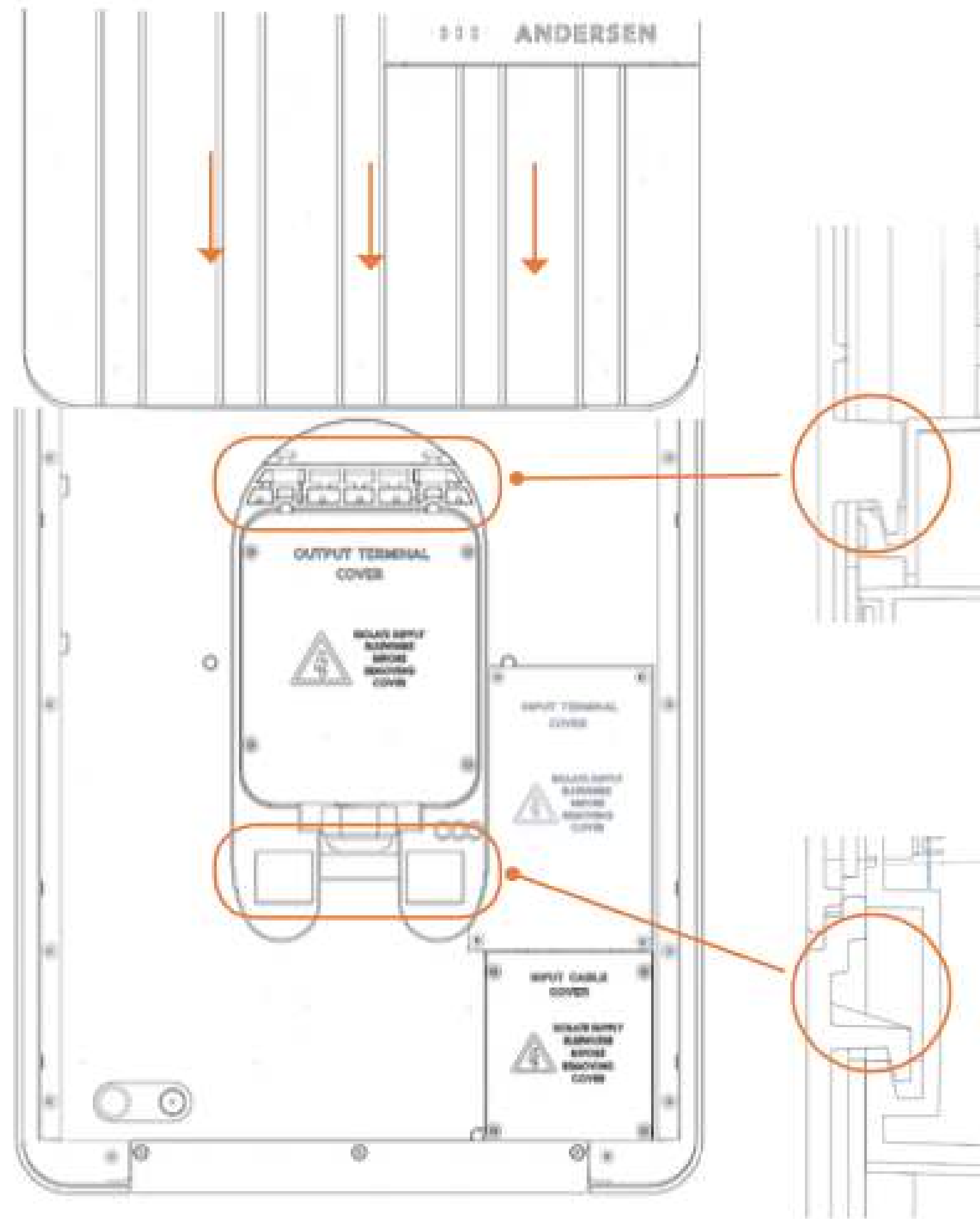

A: Ensure the front panel mounts are located into the slots correctly



B: Insert and tighten front panel screws correctly torqued to 2.5nM

Technical Data	
Mounting Location ¹	The mounting wall must be capable of supporting at least four times the weight of the unit (44kg) and must be fire resistant.
Charging Mode	Mode 3 (IEC 61851-1 complaint communication protocol)
Display	Status lights- Warm white, Hall sensor operated and internal courtesy light.
Charging Current	Single Phase / 3 phase units 6A to 32A Per Phase
Variable Current	Single Phase Only 6A - 32A CT Monitored (Adaptive Fuse)
Connector Type	Type tethered cable IEC 62196-2 compliant
Compliance	RED 2014/53/EU, LVD 2014/35/EU, EMC 2014/30/EU, EN 61851-1:2019, EN 62196, EN 62955:2018, ROHS 2011/65/EU, WEEE 2012/19/EU, CE and UKCA Certified.
Ingress Protection	Enclosure, core and plug compartment IP65.
Operating Specification	Humidity to 95% RH non condensing -25 Celsius to +40 Celsius
Security	Remote software enabled charge point locking, 128-bit data SSL AES encryption for smart connectivity, Bluetooth with TLS encryption.
Fault Monitoring	Realtime health monitor system, start-up self-test, Earth monitoring, Welded contactor monitor, PME monitoring.
Enclosure Core Material	Polycarbonate Blend
Finish Material	Aluminium Nylon Coated, Accoya
Shipped Weight	15-16kg

Electrical Specifications	
Rated Power	7kW (1-phase) / 22kW (3-phase)
Rated Supply Voltage	230V AC Single Phase or 400V AC 3-Phase (+/- 10%)
Operating Voltage / Frequency	207V - 253V AC at 5Hz
Rated Current	32 Amps
PEN fault detection	Conforming to 722.411.4.1 (iii) (iv)
Earth Leakage Protection ²	Internal 6mA DC protection (EN 62955)
Standby Power ³	10 Watts
CT Sensor Voltage	0.333V
CT Sensor Specification	0 - 120 Amps / 25mm ² maximum cable size split core
EVOFLEK Charging Cable ⁴	4mm ² Live Conductors / 32 A max current. High Performance ultra flexible cable
Installation	
Mounting	Flush mounting location using 4x fixing points
Cable Entry	Rear / Bottom (Lower left below cable terminations) 20mm removable compression gland.
Cable Sizing	4mm ² - 10mm ²

Dimensions Unboxed	494 x 348 x 148 mm (metal) 156mm (wood)
Height	Installed between 0.75m - 1.2m from ground level
CT Sensor Cable	Maximum extended length 30 metres unshielded CAT5/6 OR 50 metres shielded CAT6 data cable.
Recommended Upstream Protection	40A RCBO (BSO EN 61009)) or Type A RCD / RCCB (BSO EN 61008) + 40A MCB (BSO EN 60898) - B curve for 1 phase / C curve for 3 phase.
Installed Weight	9.5kg - 11.2kg
Device Connection	
Internet Connection	Wi-Fi - 802.11 b/g/n support, 802.11 n (2.4 GHz), up to 150 Mbps
Bluetooth	Bluetooth BLE 5 (set-up only)
Device Support	Apple iOs mobile device / Android mobile devices
EVSE Regulations	Compliant with The Electric Vehicles (Smart Charge Points) regulations 2021.

1. The mounting wall must be capable of supporting at least four times the weight of unit (44kg) and must be fire resistant.
2. The mounting hardware (screws, wall plugs etc) must be selected to be appropriate for the specific structure of the mounting wall.
3. The cable used must be approved to a local national regulations and standards.
4. The upstream protection must be approved to local national regulations and standards. The disconnection devices, isolators, etc. must be nearby and easily accessible at all times.

**DANGER**

Danger to life due to electrical voltage! Injuries due to electric shock! and/or burns, possibly resulting in death, are possible.

During all work, make sure at all times that power to the system is switched off and secured so it cannot inadvertently be switched on.

- Before commissioning the device, check that all screw and terminal connections are tight.
- The termination panel covers must never be left opened without supervision. Fit the termination panel cover when you leave the charge point.
- Do not make any unauthorised changes or modifications to the charge point
- Repair work to the charge point may only be completed by the manufacturer or a trained expert.
- Do not remove any identifiers such as safety symbols, warning instructions, rating plates, labels or cable markings.
- Ensure that the charging cable is not mechanically damaged (kinked, jammed or run over) and that the contact area does not come into contact with heat sources, dirt or water.

**WARNING**

Safety notice:

- Switch off on all poles and from all sources.
- Secure to prevent it being switched on again.
- Verify isolation from the supply.
- Earth and short-circuit.
- Cover neighbouring live parts and cordon off danger areas.

**CAUTION**

Ensure that the charge point is not damaged by incorrect handling (housing cover, internal parts, etc.)

On outdoor installations, do not open the termination panel cover in damp conditions.

- Do not tighten the securing screws with force.
- The installation area must be completely flat, do not bend the housing.
- Electronic components may be damaged if handled. Before handling modules, perform an electrically discharge process by touching a metallic earthed object.

A failure to follow the safety information may result in a danger of death, injury and damage to the device. The device manufacturer cannot accept any liability for claims resulting from this.

We're here to help

Send us an email

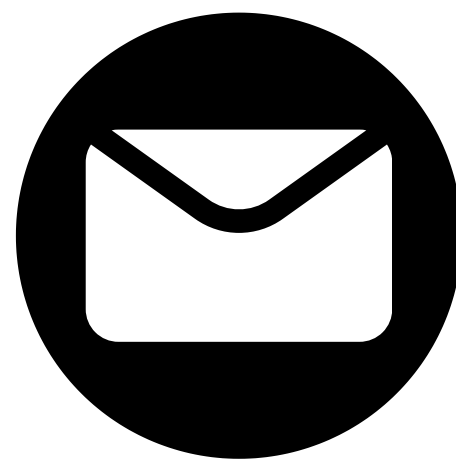

helpdesk@andersen-ev.com

Call us

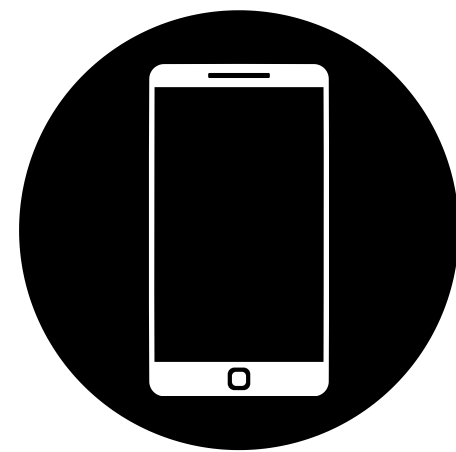

Mon-Fri 08:00 - 19:00

Sat 09:00 - 14:00

+44 (0) 1234 916125

www.andersen-ev.com