

A

B

C

D

E

F

BILL OF MATERIAL			
ITEM	PART NUMBER	DESCRIPTION	QTY
1	EVA-001	EV FOUNDATION	1
2	EVA-002	EV PLATE	1
3	BOLT 4012180	HEX SOCKET HEAD CAP M12 x 180	2

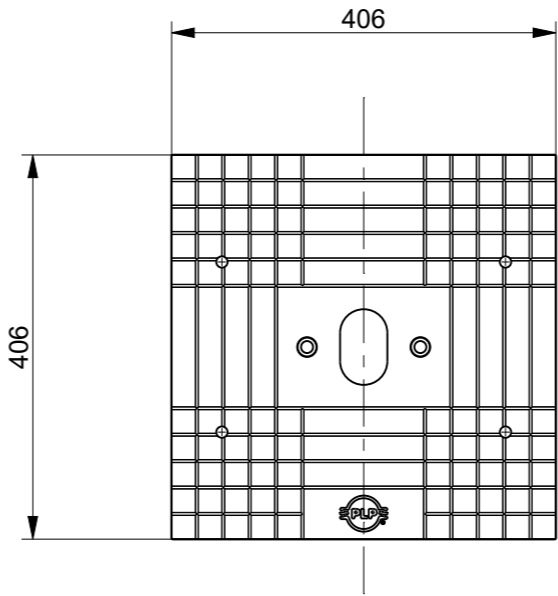
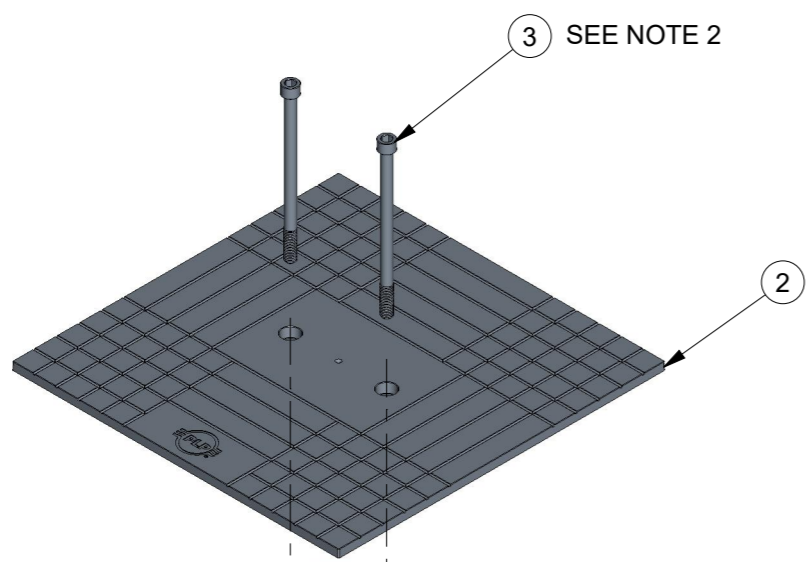

NOTES:

- 1. CHECK ALL COMPONENT PLACEMENT AND QUANTITY.
- 2. BOLT TORQUE: HAND TIGHT.
- 3. APPROX WEIGHT: 21kg

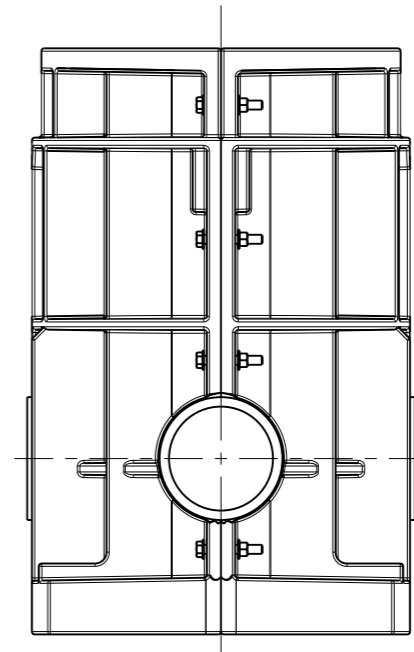
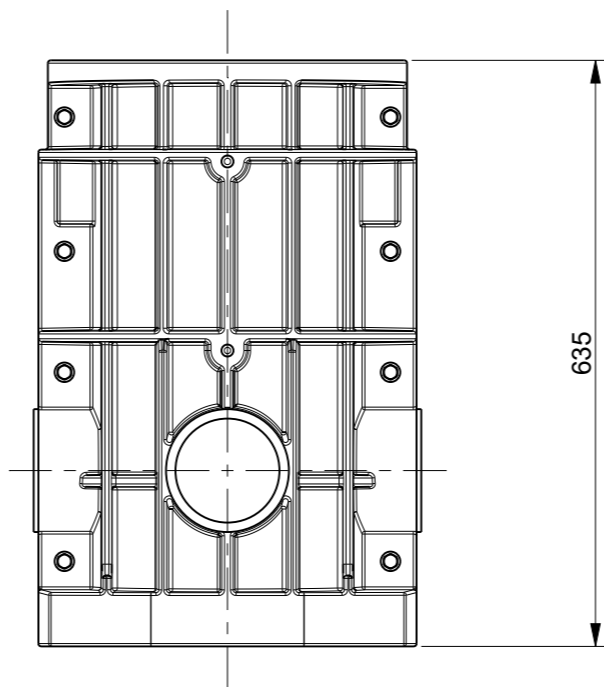
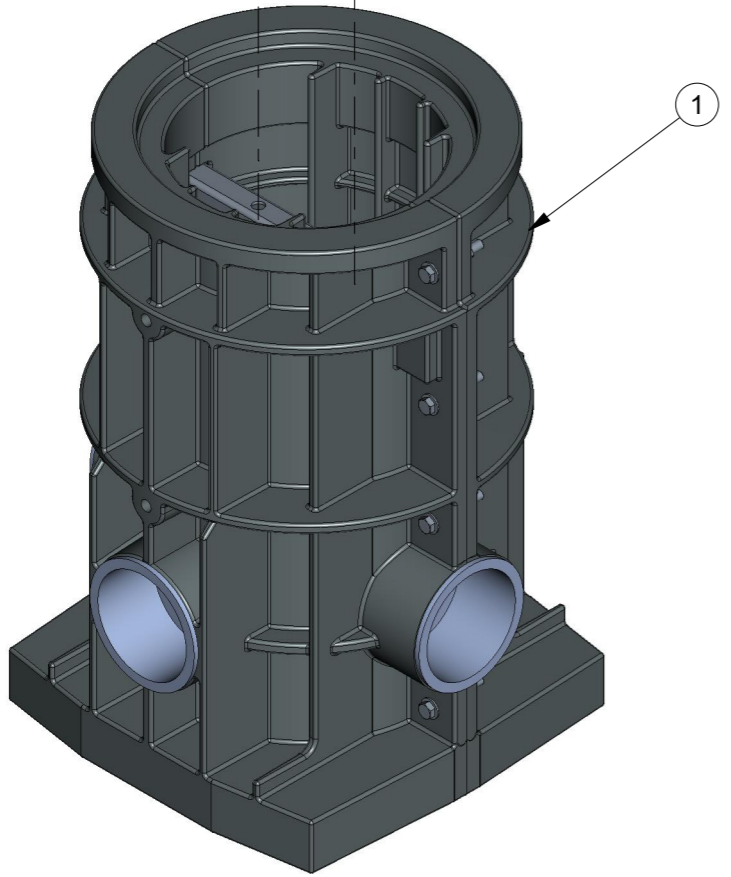

REV	REV DATE	DRWN	APVD	APVD	DESCRIPTION
A	07.03.2023	AS	AS	AS	FIRST ISSUE
CUSTOMER DRAWING TITLE					TOLERANCES UNLESS NOTED
EV BASE ASSEMBLY					$\leq 35\text{mm} \pm 0.7\text{mm}$ $> 35\text{mm} \pm 2\%$
					UNITS: mm DO NOT SCALE THIRD ANGLE PROJECTION



ANDOVER, HAMPSHIRE, UK
 +44 (0) 1264 366234
 PLP.COM

CONFIDENTIAL THIS DRAWING IS THE EXCLUSIVE PROPERTY OF PREFORMED LINE PRODUCTS COMPANY (PLP) AND IS TO BE USED ONLY WITH THE PRIOR EXPRESSED PERMISSION OF PLP			
DRWN: AS	DATE: 07.03.2023	PLP CATALOG NUMBER	PLP PART NUMBER: EV-001
APVD: <i>AS</i>	DATE: 07.03.2023	CUSTOMER I.D. NUMBER	PLP DRAWING NUMBER: EV-001
APVD: <i>AS</i>	DATE: 07.03.2023	SCALE: N.T.S.	SHEET No: 1 OF 1
			ORIGIN: A