

Indra Smart Range

Installation Guide

Be at the forefront of EV charging with
Indra's pioneering technology



Contents

Products in the Range	4
Smart PRO Tethered	4
Smart PRO Untethered	4
Smart LUX™ Tethered	5
General Description	5
General Warnings and Safety	6
Overview and Intended Use Environment	7
Smart Features	8
Boost	8
O-PEN Fault Detection	8
House Fuse Protection (Load Curtailment)	8
DC Leakage Protection	8
Tariff Intelligence	9
Solar Mode	9
Smart Scheduling	9
Over-The-Air Updates	9
Charge Analytics	9
Protective Earth, Simultaneous Touch (PESTs) Protection	10
General Installation Notes	12
Charger Layout	13
Smart LUX™	13
Smart PRO	14
Pre-Installation Survey	15
Installation Procedure	16
Procedure	16
Switchgear	16
Choosing the charger location	17
Wall Mounting	17
Hanging the charger	18
Smart LUX™ storage hook	18

Cable Entry	19
Smart LUX™	19
Smart PRO	20
Connect Mains Cables	21
Smart LUX™	21
Smart PRO	22
Installing a Reference Pin	23
Connectivity	24
Wi-Fi	24
Wi-Fi Pairing	25
Hardwired	26
4G	27
4G Pairing	27
External CT Clamp	28
Testing	29
Continuity of Protective Conductors	29
Insulation Resistance (IR)	29
Polarity	29
Earth Electrode Resistance Testing	29
Earth Fault Loop Impedance (EFLI) Verification	29
RCD Testing	30
Sealing the Unit	31
Commissioning	32
Customer Handover	33
Charger Familiarisation	33
Customer Support	33
Wire Cut Lengths	34
Troubleshooting	34
Meaning of 4G Dongle LEDs	32
Turbine Lights	33
What the LEDs on the charger mean	37

Products in the Range

Smart PRO Tethered

Smart PRO Type 2 (SPRFGTWG102) has an IEC 62196 (Type 2) 6M tethered charging connector to be used with Type 2 socket fitted EVs.



Smart PRO Untethered

Smart PRO Type 2 Untethered (SPRFGSKWG103) has an IEC 62196 (Type 2) socket as part of the front body.



Smart LUX™

Smart LUX™ Tethered has an IEC 62196 (Type 2) tethered charging connector to be used with Type 2 socket fitted EVs.

It comes with either a 6m or 10m tethered lead and a variety of coloured fascias.



General Description

This manual describes the method of installation and hardware operation of the Indra Smart Range, where the charger is a permanently installed electric vehicle charging solution for resistive domestic and commercial loads of at least 6A and up to 32A at 230V, 50Hz.

Smart LUX™ Product Codes:

SMNFGT2WH401	Indra White, 6m
SMNFGT2WH402	Indra White, 10m
SMNFGT2BL401	Symphony Black, 6m
SMNFGT2BL402	Symphony Black , 10m
SMNFGT2GY401	Malvern Stone, 6m
SMNFGT2GY403	Malvern Stone, 10m
SMNFGT2GY402	Elgar Grey, 6m
SMNFGT2GY404	Elgar Grey, 10m



General Warnings and Safety

- The Smart Range should only be installed and maintained by a suitably competent electrician who has successfully completed Indra product training. Failure to comply will VOID the product warranty.
- The Smart Range is designed for permanent installation and should only be used within the parameters set out in the technical specification and on the product label.
- The Smart Range should be installed in accordance with the latest wiring regulations (BS7671).
- Use of an upstream O-PEN protection device is NOT permitted with Indra Smart Range. Use of such devices will VOID the warranty.
- Before commencing installation or maintenance, the electrical power supply MUST be safely isolated.
- The Smart Range should be installed in a location that is structurally sound and free from excessive vibration, dust, or other material build up that could affect normal operation.



Overview and Intended Use Environment

Indra Smart Range can be classified as a 'smart' electric vehicle charging solution because of the communications infrastructure which allows charging to be remotely optimised by the Indra App; where charging can take place when electricity is cheapest; or if immediate charging is required, its 'Boost' functionality overrides any smart grid criteria and provides instantaneous charging capability.

Charging using Indra Smart chargers can take place at up to 7.4kW, but due to modulation capability (measured by the external CT clamp) this power output level can also be reduced.

The Smart Range are intended for both indoor and outdoor installation, securely mounted to a wall or appropriately pedestal.

In its operating environment, the temperature must be between -20°C and 50°C, with humidity between 10% to 85% non-condensing.

The supply to the charger should be 230V AC +10/-6%, 50HZ and rated $\geq 32A$ for maximum charging capacity.

Indra Smart Features

Boost

Fundamental function of the charger that enables the user to charge the car when the charger is offline, or to override any set schedules. This function is most often used when the user needs the car charged earlier than normal.

O-PEN Fault Detection

Indra Smart Range have built-in O-PEN protection in the form of Indra's patented PESTs. This offers multiple options to comply with the PEN fault regulations, including Line to Neutral Voltage monitoring (PEST mode B) and CPC to true earth voltage monitoring (PEST mode A).

(For more information see the PESTs section).

House Fuse Protection (Load Curtailment)

Is a function that allows an EV charger to be installed at a property that may not have enough spare capacity to accommodate the charger always running at full power.

It works by monitoring the amount of power the installation is using via an external CT clamp and comparing that to the rating of the main cut-out supplying the installation. If the difference is greater than 32A then the charger will offer full charge. If the difference is less than 32A then the charger will only offer as much power as there is spare capacity on the main cut-out.

Note: G100.2 defines how load curtailment is managed. If the charger is configured to use load curtailment and it loses contact with the external CT clamp, then the charger will de-rate its power output to 6A to protect the main cut-out, thus 6A is the figure that should be considered when carrying out the maximum demand survey.

DC Leakage Protection

An RDC-DD is fitted into Indra Smart chargers, offering 6mA DC leakage protection. This means they should be installed with a Type A or type F RCD up stream.

Tariff Intelligence

This feature enables the customer to tell the charger what electricity costs them and when, the charger will charge the car at the cheapest times. This feature is also compatible with all time of use tariffs including agile.

Solar Mode

This mode can be selected in the Indra App and can enable the customer to use any excess solar energy (or any other form of micro-generation) to charge their car.

The external CT monitors how much energy is being exported from the installation. If the installation is exporting more than 1.4KW, then the charger will offer the car a charge. (1.4KW is the minimum amount of power required for an in-car charger to accept a charge).

Note: The external CT clamp can only measure what energy is being exported back to the grid, therefore, if the micro-generation is generating 2KW, and the installation is using 1KW, the charger will only detect the remaining 1KW being exported to the grid. This means the charger will not offer a charge to the car because there isn't enough power to trigger the in-car charger (1.4KW). Export to the grid needs to be 1.4kW or greater before the car will be offered charge.

Smart Scheduling

Smart scheduling allows the user to create a schedule window - this is when the charger will start and stop charging - but also, how many miles to add, how many kWh to add or how much money's worth of energy to add to the car.

Over-The-Air Updates

The Smart Range can be updated via an internet connection to the charger. These updates can offer improvements to the function of the charger, pre-emptive fixes for identified issues, or can be used to rectify faults if they occur.

Charge Analytics

The Indra App offers the user detailed information about the behaviour of their charger and their charging history, including how much money they have spent, how many miles have been added to the car and overall usage.

PEN Fault, Earthing, Simultaneous Touch (PESTs) Protection

The Smart Range PESTs solution can operate under three of the indents of BS7671:2018 A1:2020+A2:2022; section 722.411.4.1. For the purposes of design/installation we have two modes of operation which Indra call A & B. Mode A can be configured with or without a reference pin. The safest installation configuration is mode A with reference electrode.

Mode A with reference pin – (Compliant to BS7671:2018, regulation 722.411.4.1, Indent iii)

This method monitors the voltage difference between Circuit Protective Conductor (CPC) and true earth, disconnecting the car from the charger in the event of the voltage difference rising above 30Vrms. It also measures the voltage between L, N & CPC between 184v-257.6v (230v +/-12%).

What it means:

- Removes the risk of nuisance tripping due to supply voltage fluctuations (e.g. voltage spikes due to energy export to the grid),
- Compliant install on a 3-phase supply,
- Prevents potentially dangerous voltages from occurring on the car chassis under any circumstances,
- Removes simultaneous touch risks between the charger/connected car and conductive parts connected via TT (e.g. lamppost).

Mode B – (Compliant to BS7671:2018, regulation 722.411.4.1, Indent iv)

Monitors the L-N voltage and will disconnect from the car if the voltage goes out of range (253V-207V). Protected Multiple Earth (PME) is used as the CPC, and no earth rod or reference pin is required if there are no simultaneous contact or touch voltage risks present.

Consideration should be given to nuisance trips where the line to neutral voltage may exceed 253V, especially where local renewables are present.

Mode A without reference electrode

Used for installations that do not fall under the requirements of 722.411.4.1 E.g. TT installations; installations where the charger and car will be indoors when charging; installations where PME is bonded to Earth in accordance with BS7671:2018; regulation 722.411.4.1, Indent ii.

PEST's Decision Workflow

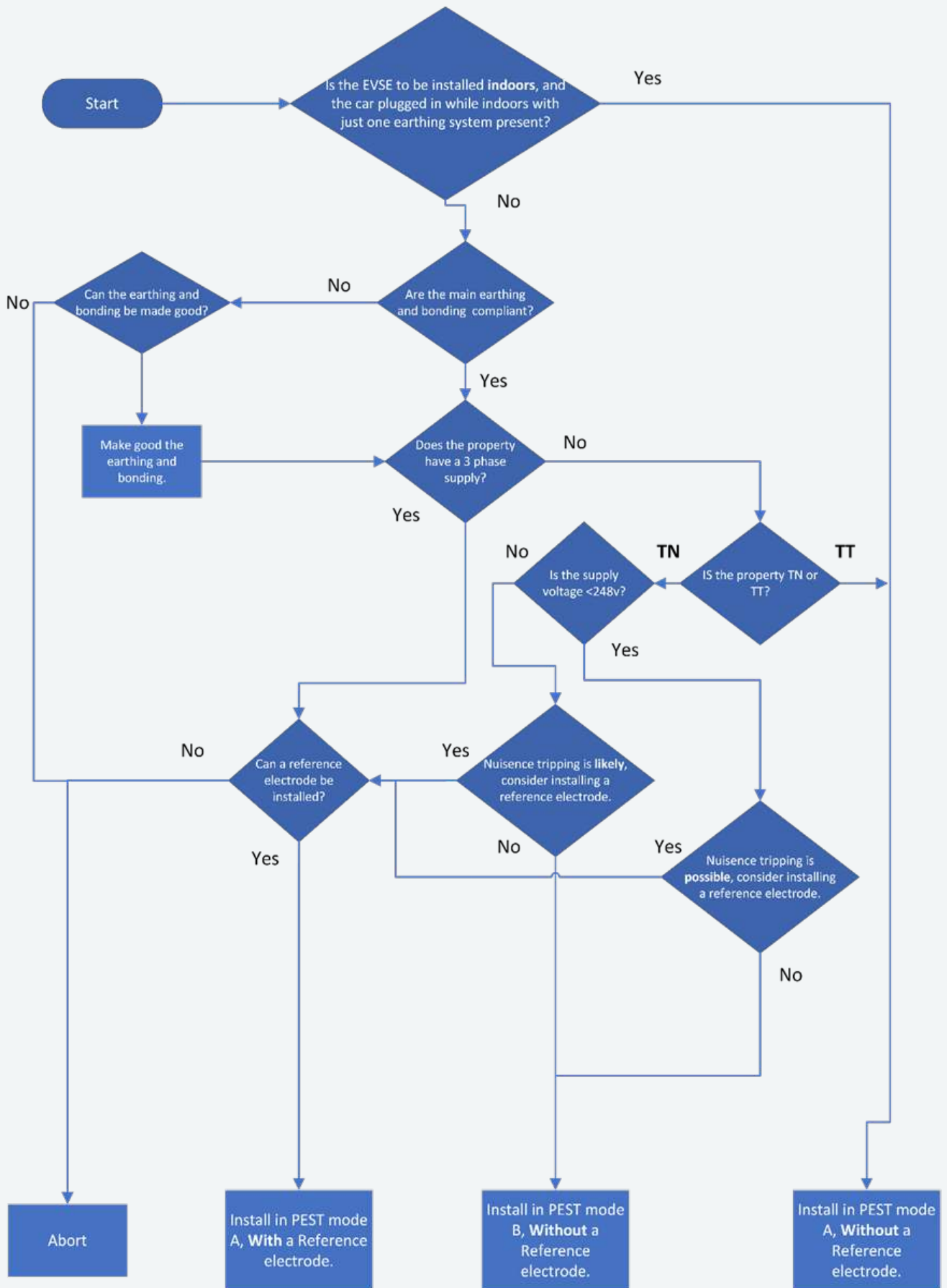

General Installation Notes

WARNING: FAILURE TO COMPLY WITH THESE INSTRUCTIONS COULD PRESENT A HAZARD

- A. The Indra Smart Range must be installed by a qualified electrician who has completed Indra Academy Training. Any servicing or tampering by a non-qualified professional electrician WILL void the warranty.
- B. Read these instructions fully before installing an Indra smart charger.
- C. The power supply MUST be isolated and checked for dead before installation or maintenance.
- D. The Indra Smart Range chargers are designed for permanent installation and is suitable for operation on an AC electricity supply having the same voltage and current rating as shown on the product label.
- E. The chargers should be installed in accordance with extant wiring regulations.
- F. The charger MUST NOT be fitted alongside an upstream protection device which claims to meet ident (iv) of BS 7671:2018+A1:2020+A2:2022; section 722.411.4.1. Voltage upstream PEN Fault protection and curtailment devices may damage the device through frequent removal of the grid supply under load.

WARNING: Protection against electric shock shall not be automatically reset.

- G. The charger MUST be connected to CPC (either supplied from a PME or TT earth).
- H. The installation location MUST be structurally sound and MUST NOT be subject to excessive dust, vibration, lint, or other material build-up which could affect the charger's proper operation.
- I. The customer should have agreed to the position of the charger and any additional enclosures, and cable routing.

Charger Layout - Smart LUX™

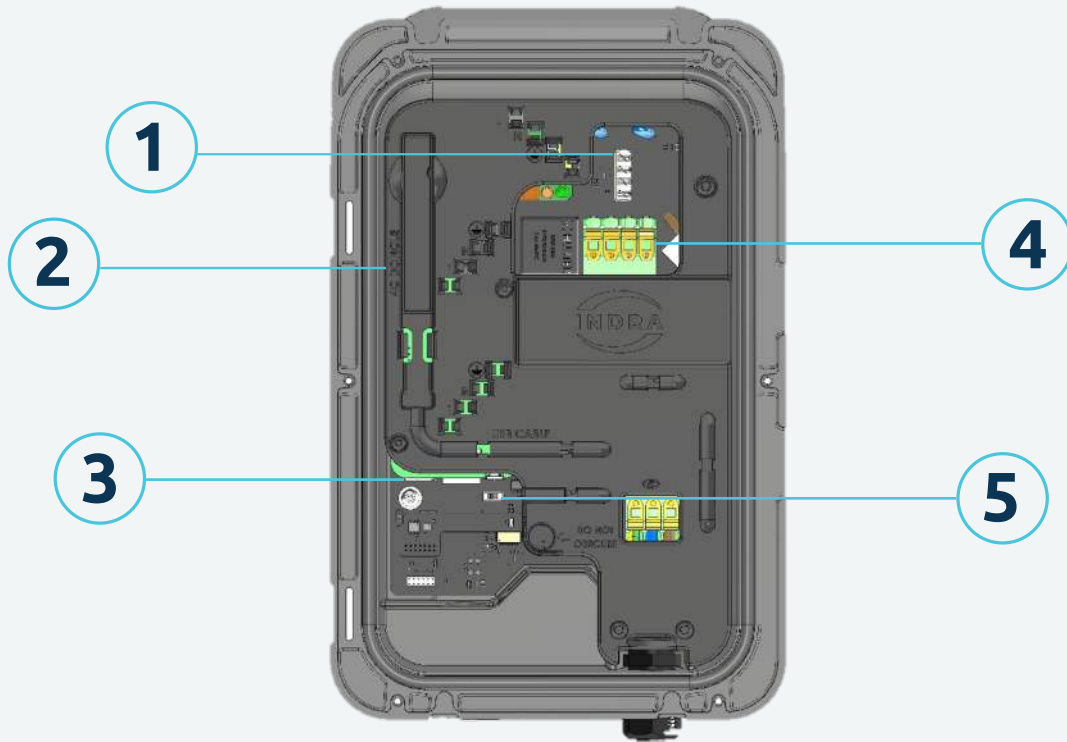

- 1** CT Connections
- 2** Wireless Dongle
- 3** USB & RJ45
- 4** Live Neutral REF CPC
- 5** PESTs Mode Switch

Charger Layout - Smart PRO

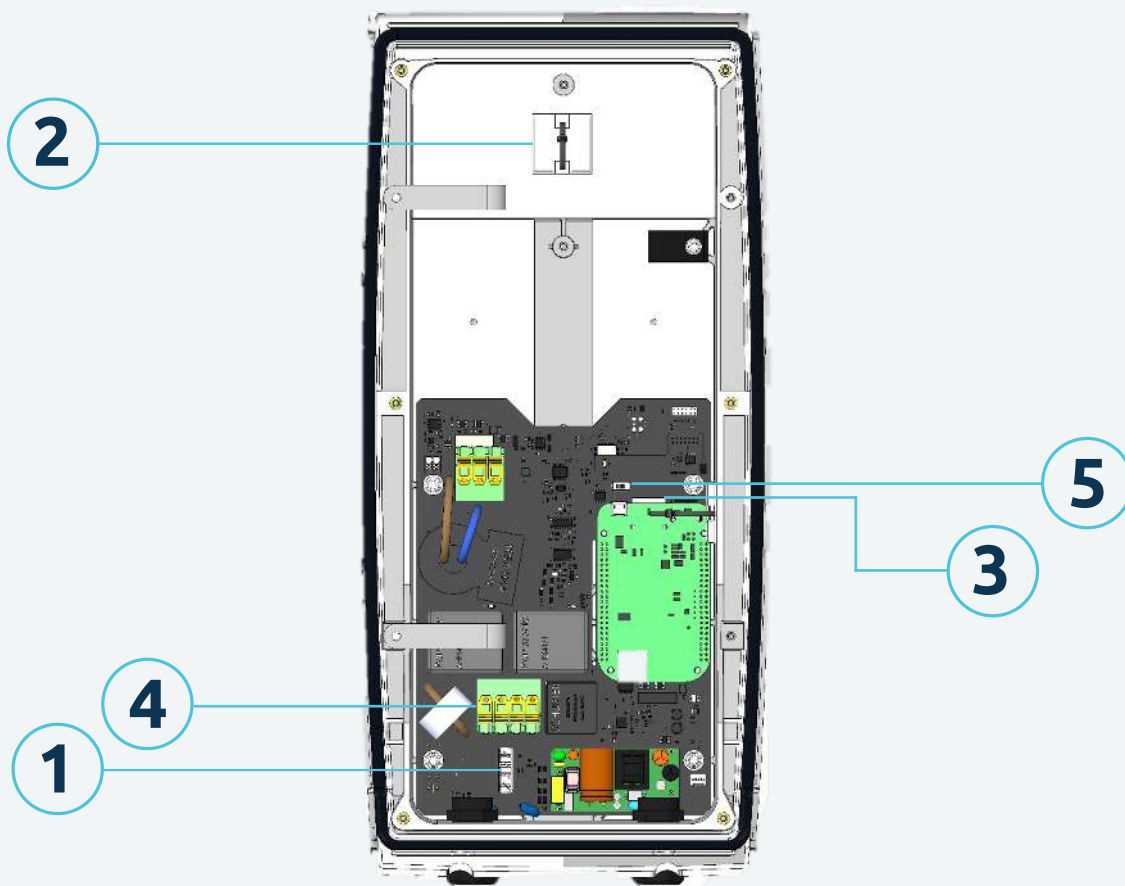

- 1** CT Connections
- 2** Wireless Dongle
- 3** USB & RJ45
- 4** Live Neutral REF CPC
- 5** PESTs Mode Switch

Pre-Installation Survey

Before installing an Indra smart charger, we recommend surveying the installation to ensure that an install can go ahead and that the charger is appropriate for the customers' requirements.

This survey should include:

- Identify the earthing arrangement of the property and the required PEST mode.
- If a reference electrode will be required, identify a suitable location for it.
- Establish the maximum demand of the existing installation and compare this with the rating of the main cut out supplying the property. If there is less than 32A capacity remaining, then the Load Curtailment feature on the charger will be required. you should account for a load of 6A for the charger when load curtailment is being used.
- If Load Curtailment or Solar Mode is required by the customer, establish where the external CT would be placed.
- Identify which connectivity method would be most appropriate.
- Ensure Wi-Fi and Cellular network signal strength is sufficient for the function of the charger. Required 4Mb.
- Identify a suitable location for the charger, with agreement from the customer.

Installation Procedure

Indra smart chargers are supplied with the general screws and wall fixings that are required to permanently fix them in position. However, it remains the responsibility of the installer to evaluate the suitability of the installation surface and use the appropriate fixing.

Procedure

- All parts of the existing installation that will comprise part of the EVSE charging circuit, must be inspected for damage, be suitably rated and compliant with the appropriate regulations.
- Ensure installation earthing conductors are tested and compliant with the latest BS 7671 wiring regulations.

WARNING: ANY DAMAGED OR UNSUITABLE CABLES OR EQUIPMENT MUST BE REPLACED

- Inspect the charger to ensure it has not been damaged in transit and is safe to connect.

Switchgear

Indra smart chargers require an upstream type A or F RCD to be fitted.

Indra recommend installing the following equipment upstream to minimise potential nuisance tripping and to ensure compliance with BS7671:2018 A1:2020+A2:2022 section 722. (These requirements can be met in whatever configuration suits your design).

- a) Type A 30ma Double Pole RCD protection
- b) C Curve 40A Overcurrent protection

In accordance with BS 7671:2018 A1:2020+A2:2022 Regulation 443.4.1 a surge protection device will need to be installed to protect the charger unless the customer has signed a waiver acknowledging they accept the risk of any potential damage caused.

Choosing the Charger Location

- Select an installation location that ensures future servicing of the Indra Smart charger, where the back plate can be mounted flush to a flat wall and screws can be used to permanently secure the charger in position.
- Make sure the install location will not allow any flammable material to come within 100mm of the unit.
- The control panel of the unit should be installed between 0.75m - 1.20m from the ground.
- The charger should be placed such that the potential risk of tripping over trailing charging leads is minimised as far as reasonably practicable.

Wall Mounting

Note: The fixing holes in the bracket are spaced to meet standard brick sizes so they can all fall within a brick centre.

- Offer the mounting bracket against the surface you intend to fix to and level using a spirit level.
- Mark and drill four holes with a 6mm drill bit (Masonry/5mm Plasterboard).
- Secure to the wall with four fixings.

Hanging the charger

- Hold the top of the charger just above the wall bracket tilted upwards away from the wall.
- Lower the charger onto the two prongs at the top then hinge the charger back flush with the bracket.
- Secure the charger to the bracket with the 4x8mm button head T20 Torx screws into the bottom of the charger with a T20 screwdriver. Torque setting 2.0-2.5 N/m. Carefully remove the front of the charger and hinge it to the side to allow access, the front body is secured to the main body to protect the ribbon cable to the front panel PCB. Do not remove or detach.

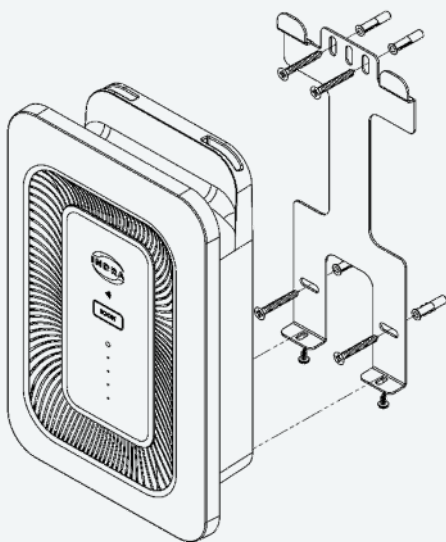

Figure 1: Smart LUX™ Wall Mounting

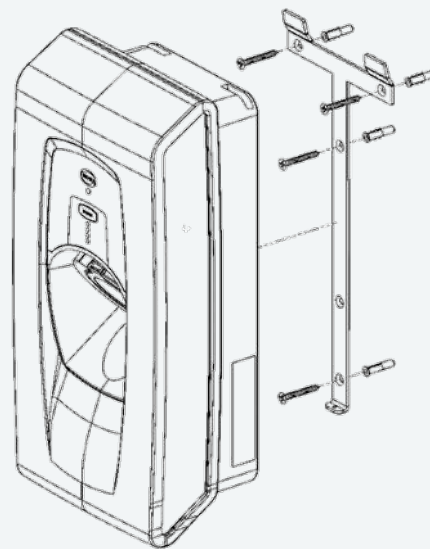

Figure 2: Smart PRO Wall Mounting

Smart LUX™ Storage Hook

The Smart LUX™ Storage Hook should be fitted in close proximity to the charger to enable the tethered charging cable to be stowed on it.

The cable hook should be secured with the supplied fixings as per Figure 3

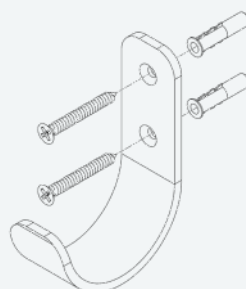

Figure 3: Cable Storage Hook

Cable Entry - Smart LUX™

The Smart LUX™ is designed with two cable entries in the bottom edge and one in the rear (Identified in blue on Figure 4).

- All cable entry points are designed for a 25mm hole.
- Install a 25mm IP68 rated gland for the cable identified in the circuit design.

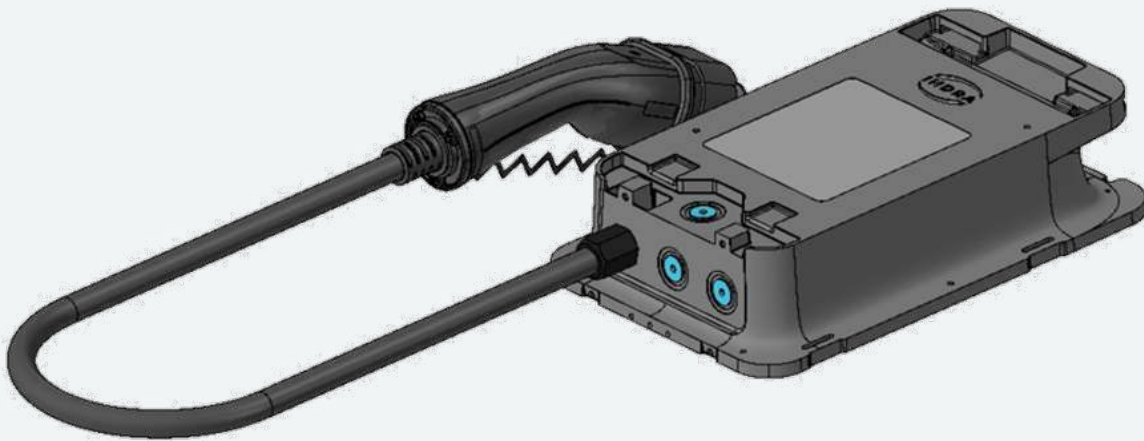

Figure 4: Smart LUX™ Cable Entry

Cable Entry - Smart PRO

The Smart PRO is designed with four cable entry points, two in the bottom edge and two in the rear (Identified in blue on Figure 5).

- Cable entry point 1 is designed for a 25mm hole.
- Cable entry point 2 is designed for a 20mm hole.
- The rear entry points are designed for a 25mm hole.
- Install the appropriately sized IP68 gland for the cable used.

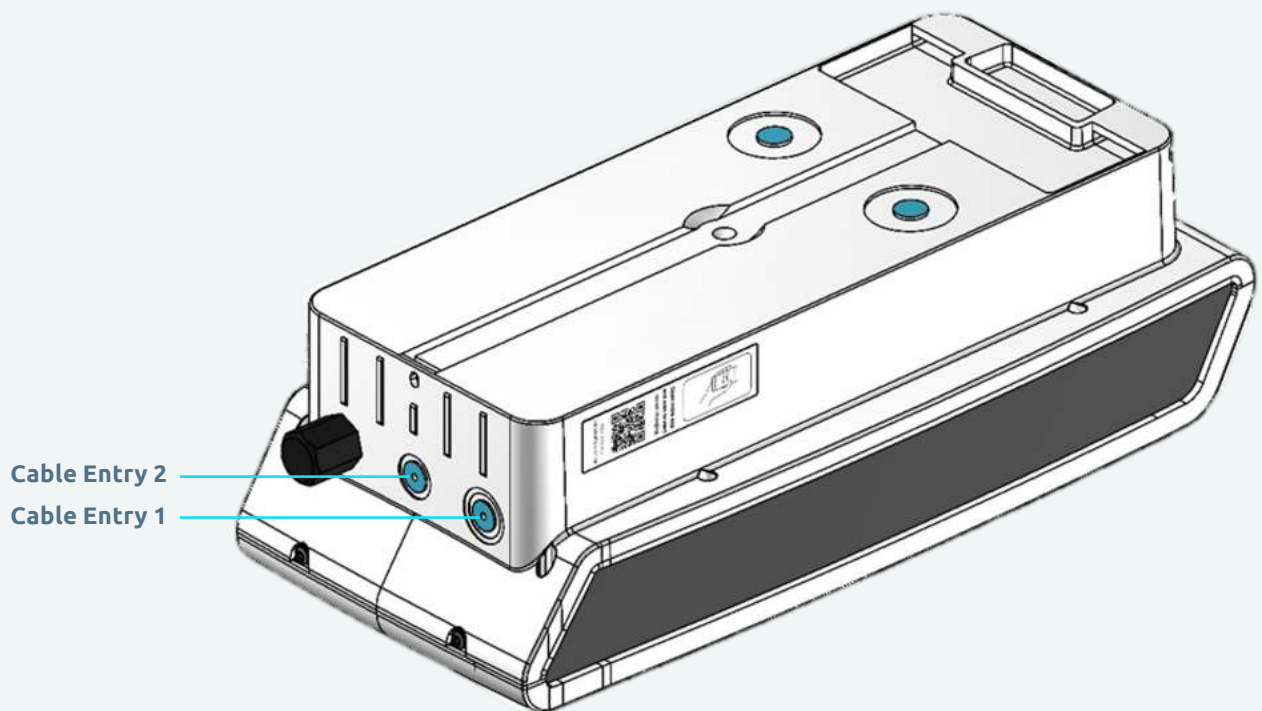

Figure 5: Smart PRO Cable Entry

All swarf and shavings should be removed from the charger and the hole deburred.

Connect Mains Cables - Smart LUX™

Note: Cut the mains wires with reference to the Wire Cut Length table.

- Remove the outer insulation of the cable, leaving 10mm showing at the gland.
- Route the wires as per Figure 6.
- Insert wires into the lever type connectors labelled L (Live), N (Neutral) and CPC (Circuit Protective Conductor).

Note: Indra recommend the use of bootlace ferrules on class 5 & 6 cables ONLY.

Note: Indra recommend using EV Ultra Cable from Doncaster Cables as it contains power and data in the same cable.



Figure 6: Smart LUX™ Mains Cable Routing

Connect Mains Cables - Smart PRO

Note: Cut the mains wires with reference to the Wire Cut Length table.

- Remove the outer insulation of the cable, leaving 10mm showing at the gland.
- Route the wires as per Figure 7.
- Insert wires into the lever type connectors labelled L (Live), N (Neutral) and CPC (Circuit Protective Conductor).



Figure 7: Smart PRO Mains Cable Routing

Installing a Reference Pin

When using PEST Mode A, a reference to true earth is required to protect against O-PEN faults in the distribution network. This reference allows for voltage to be measured between the installation earth (CPC) and true earth, so that if CPC becomes live because of a broken PEN, the voltage will be detected and the charger will disconnect Live, Neutral and CPC from the car.

The reference pin is NOT a fault path, thus does not need to comply with the requirement for a TT earth electrode.

The reference pin should be a copper plated 3/8" electrode with a lug terminal clamp.

- If installing straight into soil or equivalent soft terrain, then the electrode can be cut down, to reduce the necessary length driven into the ground (as short as 300mm). For hard aggregate, it may need to be longer.

Before driving the pin into the ground, ensure there are no buried services in the area.

- Drive the pin straight into the ground, leaving enough length at its tip to secure the clamping terminal.
- Attach the lug clamp terminal and run a length of cable (Indra recommend solar PV cable) back to the charger.
- Terminate with a bootlace ferrule (Class 5 & 6 cable only) in the lever type connector labelled "REF". (As shown in Figure 8).

Note: Cut the reference cable in accordance with the Wire Cut Length Table (Page 34).

Note: Indra recommend the use of Solar PV cable (EN5061) with double insulation.

- Using a Multi-Function Tester or electrode tester, measure the resistance of the newly installed reference pin and ensure it is less than **600Ω**.



Figure 8: Reference Connection

Connectivity

Wi-Fi

The Smart Range can be connected to the internet via a Wi-Fi dongle installed inside the charger. This method is ideal when data cable routing to the router is not feasible, or the customer wants to reduce visible cables.

- Before installing a Wi-Fi dongle, check the speed and strength of the Wi-Fi signal at the charger location. This can be done by connecting your phone or tablet to the customer's Wi-Fi and run a signal speed checker. The Smart Range requires a minimum of 4Mbps.

Note: The Wi-Fi dongle connects to the customer's router via the WPS function. If the customer's router doesn't have a WPS button, most can activate WPS remotely from the router settings.

- Connect the USB cable supplied with the dongle into the Beaglebone and route as per Figure 9 or 10.
- Connect the dongle and secure as per Figure 11 or 12.

Connecting the charger to the Wi-Fi can be carried out after the charger has been sealed and powered up.

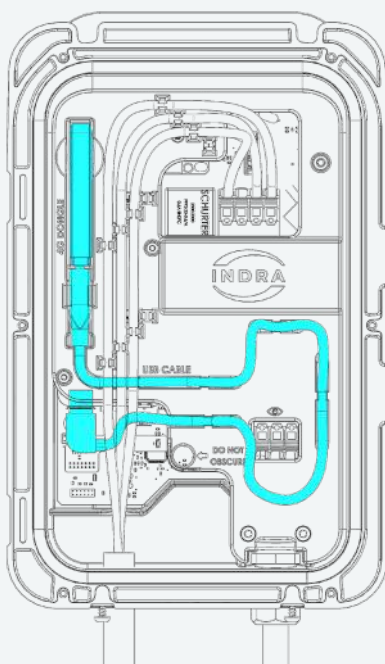

Figure 9: Smart LUX™ Dongle Routing

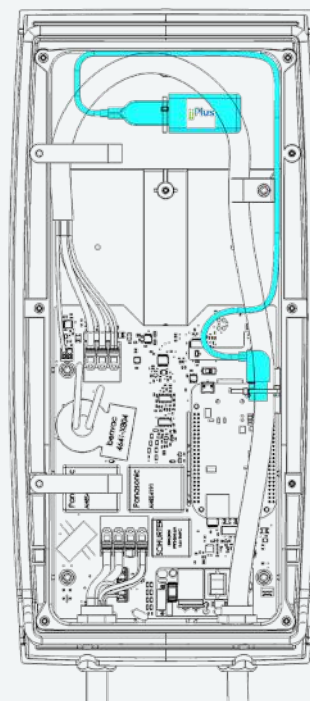

Figure 10: Smart PRO Dongle Routing



Figure 11: Smart LUX™ Dongle Placement



Figure 12: Smart PRO Dongle Placement

Wi-Fi Pairing

1. Press and hold the BOOST button until the Primary LED turns orange.
2. Release the BOOST button (before it turns green).
3. Set Router to WPS mode (refer to Router instructions on how to do so).
4. The main LED will flash orange whilst Pairing is taking place.
5. When successfully paired the main LED will flash green for 5 seconds, before reverting to its last state, whether awaiting commissioning (Flashing white) or successfully commissioned (Solid white).

Note: The above routine times out in 2 minutes and the LED will turn red if unsuccessful.

Hardwired

Note: Indra recommend the use of hardwired internet back to the customer's router as the best option based on reliability.

- Route a cable from the customer's Wi-Fi router back to the charger and use an appropriately sized IP68 gland to enter the bottom of the charger.

Note: If using EV Ultra with CAT5e data cable built in, the orange and green pairs of wires can be terminated into an RJ45 connector and used for the internet connection, and the blue pair used for the CT clamp. This means you would only need to route a separate data cable from the router to the maintenance free enclosure the CT clamp is terminated into.

Note: Cut the data cable for hardwired internet with reference to the Wire Cut Length table

- Ensure data cable is routed as per Figure 13 or 14.
- Terminate the required data cable pairs into an RJ45 connector.
- Using a network tester, confirm correct connection order and continuity of the data cable before connecting at either end.
- Connect the RJ45 connector into the RJ45 socket on the Beaglebone as per Figure 13 or 14.



Figure 13: Smart LUX™ Data Cable Routing



Figure 14: Smart PRO Data Cable Routing

Note: It isn't feasible to get a data cable back to the customer's router, you can use a Wi-Fi extender with an RJ45 socket built in and plug into that.

4G

The Smart Range can be connected to the internet via a cellular, 4G dongle fitted inside the charger. This method is ideal when cable routing to the router is not feasible, the Wi-Fi signal strength is too weak, or the customer wants to reduce visible cables.

- Before installing a 4G dongle, check the speed and strength of the 4G signal at the charger location. This can be done by using a signal analyser. A minimum speed of 4Mbps is required.

Note: 4G internet signal strength can vary based on usage in the area; provider maintenance; and in some extreme cases, the weather. This means that connectivity can be unreliable via 4G in some circumstances.

- Connect the USB cable supplied with the dongle into the Beaglebone and route as per Figure 9 or 10.
- Connect the dongle and secure it as per Figure 15 or 16.
- Record the WCD number of the dongle during the commissioning process.



Figure 15: Smart LUX™ 4G Dongle Placement



Figure 16: Smart PRO 4G Dongle Placement

4G Pairing

Once powered up, the 4G dongle will find the strongest signal network it can. If the signal strength is strong enough, the charger will indicate it is connected to the internet by the primary LED going single White Flash (awaiting commissioning) or Solid White (successfully commissioned).

External CT Clamp

Chargers required to utilise Load Curtailment or Solar Mode features, must have an External Current Transformer fitted, so the charger can monitor total demand on the installation and total export of any micro-generation.

- The External CT clamp must be clipped around a Live cable that will enable it to measure the total import and export of the entire installation. This is usually the main tails at the meter.

Note: The smart charge regulations dictate that metering equipment for EVSE is designed in such a way as to prevent/deter tampering.

- The hard-wired cable of the CT should be routed to a location where it can be joined with a data cable. This would usually be a junction box near the switchgear of the charger circuit.

Note: Indra recommend the use of EV Ultra Cable from Doncaster Cables as it contains power and data combined in one cable.

- Using the jelly crimps provided, join the CT clamp wires to the Blue/Blue White pair of your data cable and secure it inside a maintenance free enclosure.

Data Cable Conductor	CT Clamp Contector
Blue	Red
Blue & White	White

- Route the data cable to the charger and enter the bottom through an appropriately sized IP68 gland (If using EV Ultra, it will go through the hole drilled for the power cable).
- Using an IDC punch-down tool terminate the Blue/Blue White wires into the CT connector.



Figure 17: Example CT Location

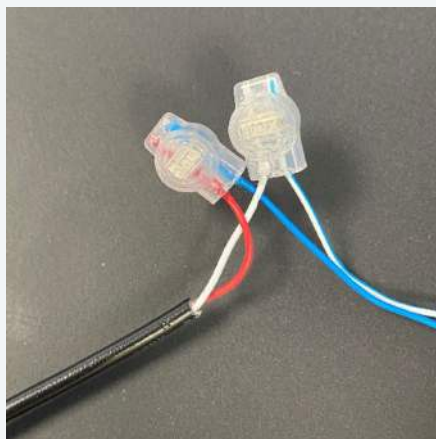

Figure 18: Data Cable Jelly Crimps

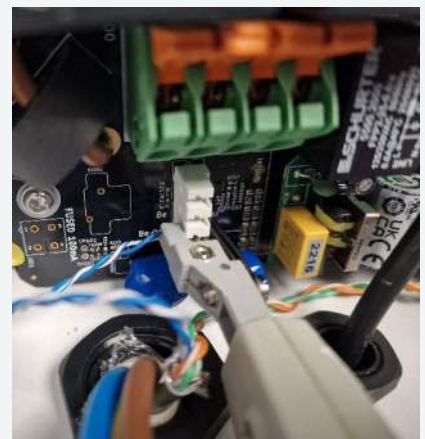

Figure 19: Charger CT Termination

Testing

All tests should be documented on an Electrical Installation Certificate (EIC).

Continuity of protective conductors

In accordance with (IAW) Guidance Note 3 to BS7671:2018+A2:2022 Section 2.6.5. This should be carried out between the live and CPC of the mains cable that will connect to the L & CPC lever connectors of the charger.

Insulation resistance (IR)

IAW Guidance Note 3 to BS7671:2018+A2:2022 Section 2.6.7, example (ii).

The Smart PRO should be disconnected from the circuit and the exposed cable end made safe before carrying out IR tests.

Polarity

IAW Guidance Note 3 to BS7671:2018+A2:2022 Section 2.6.12.

Earth Electrode Resistance Testing (If required)

IAW Guidance Note 3 to BS7671:2018+A2:2022 Section 2.6.13. This will be required when installing the charger on a TT installation or when using a reference electrode.

Earth Fault Loop Impedance (EFLI) Verification

IAW Guidance Note 3 to BS7671:2018+A2:2022 Section 2.6.15.

Zs can be measured using a multi-function tester (MFT) and a compatible Electric Vehicle Service Equipment (EVSE) tester as follows:

- Connect the MFT to the EVSE tester as per the manufacturer's instructions and set to mode A.
- Set the MFT to 6mA. If the tester does not go to 6mA then the calculation method should be used for Zs as the in-built RCD-DD protection will trigger and isolate the power relays.

- Power the charger up, once the boot up is complete, connect the EVSE tester to the charger.
- Change the mode on the EVSE tester to B, the 4 status lights should begin to flash.
- Press the boost button on the charger, the primary LED and status LED's will go blue.
- Change the mode on the EVSE tester to mode C. The status lights will go solid blue and a voltage should be indicated on the MFT
- Carry out the Loop test as per the MFT manufactures instructions.

RCD Testing

IAW Guidance Note 3 to BS7671:2018+A2:2022 Section 2.6.18.

RCD tests can be carried out at any point on the circuit e.g. on the RCD contacts or via the EVSE.

Testing via the EVSE:

Using a multi-function tester (MFT) and a compatible Electric Vehicle Service Equipment (EVSE) tester as follows:

- Connect the MFT to the EVSE tester as per the manufacturer's instructions and set to mode A.
- Set the MFT to 6mA. If the tester does not go to 6mA then the calculation method should be used for Zs as the in-built RCD-DD protection will trigger and isolate the power relays.
- Power the charger up, once the boot up is complete, connect the EVSE tester to the charger.
- Change the mode on the EVSE tester to mode B, the 4 status lights should begin to flash.
- Press the boost button on the charger, the primary LED and status LED's will go blue.
- Change the mode on the EVSE tester to mode C. The status lights will go solid blue and a voltage should be indicated on the MFT.
- Carry out the Loop test as per the MFT manufacturer's instructions.

Sealing the Unit

Once all works have been carried out inside the charger, it can be closed and sealed.

- Front cover should be secured to a torque rating of between 2-2.5 N/m with 6x 4x8mm Button Head T20 screws.
- Note: It may be worth carrying out commissioning and calibration of the charger before completing the sealing process.
- Fix the tamper seal (provided) as per Figure 20 or 21.
- During the commissioning process you will be required to input the tamper seal number.
- Fix the CT tamper seal (Red tie wrap) around the CT clamp as per Figure 22.

Note: If required, now is the time to pair the Wi-Fi dongle.



Figure 20: Smart LUX™ tamper Seal Location



Figure 21: Smart PRO Tamper Seal Location

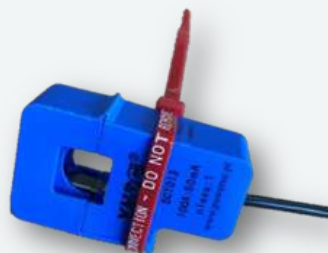

Figure 22: CT Tamper Tie Wrap

Commissioning

Once you have completed the Indra Academy training, you will receive an email containing access to DynaMO.

To begin commissioning, scan the QR code on the left side of the charger and it will take you to the DynaMO login page, then follow the installation procedure as instructed in the DynaMO portal.

DynaMO URL: DynaMo.Indra.co.uk/login

For a video tutorial on commissioning click [here](#).



Figure 23: Smart LUX™ Commissioning QR Code

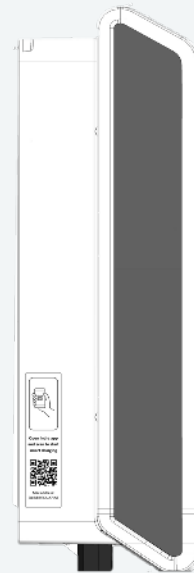

Figure 23: Smart PRO Commissioning QR Code



Figure 24: DynaMO Login Page

Customer Handover

Fill out and hand over the Smart Charge Act Statement of Compliance. Encourage the customer to retain this document as it may be used as evidence of a compliant EVSE install.

It is also recommended that the installer retains a copy, or evidence of its completion and handover, for their records.

A digital version of this form can be found on the Indra website to be emailed to the customer.

Also hand the customer the Customer Quick Start Guide. This provides them with support on getting set up on the Indra App.

Charger Familiarisation

Offer the customer a demonstration of how the charger works, for example, plug it in and show them how to start and stop a boost charge.

Show the customer where the switchgear is and how they would safely isolate or power cycle the charger if required.

Offer the customer a brief walk through of the Indra App.

Customer Support

Remember, if you have issues at any point, please contact the customer support team:

Phone: 01684 770631 (option 1)

Email: support@indra.co.uk

Monday-Thursday: 0800-1700

Friday: 0800-1600

Saturday-Sunday: Closed

Wire Cut Lengths

	Smart LUX™	Smart PRO
Live	385mm	200mm
Neutral	340mm	200mm
CPC	310mm	240mm
REF	315mm	200mm
CT	295mm	180mm

Troubleshooting

Powerline adapters

Powerline adapters should not be used on chargers that will service an MG.

4G

4G dongles have an indicating LED on the front, which shows what the dongle is doing.

To enable you to see the dongle status LED without exposing live conductive parts, dangle the dongle out of the side of the charger and loosely secure the front of the charger in place.

The 4G dongle may take up to seven minutes to connect to the internet. If it has not connected within seven minutes, power cycle the charger and try again.

If the dongle connects to a 2G signal, consider using another means of internet connection as this may not be reliable.

Meaning of 4G Dongle LEDs

Stage	Colour	Time
Bootup	Random Rainbow Colour	Roughly 20s
Looking for network	Flashing Red	N/A
2G (Ready to connect)	Flashing Green	N/A
2G (Connected)	Solid Green	N/A
3G (Ready to connect)	Flashing Yellow	N/A
3G (Connected)	Solid Yellow	N/A
4G - LTE (Ready to connect)	Flashing Blue	N/A
4G - LTE (Connected)	Solid Blue	N/A

Note:

The above table is representative of the Alcatel LinkKey 4G dongle.

Turbine Lights - Smart LUX™

The Indra Smart LUX™ is fitted with a unique set of turbine lights that correspond with the relevant colour, dependent on the user interaction. These lights trace around the full circumference of the front panel and are visible through the 'grill' of the charger.

The Turbine lights can be turned off via the Indra App at any time via the settings.



What do the LEDs on my charger mean?

There are two separate LED indicators on the charger. The Primary LED indicates the charger status, while the four panel LEDs highlight the charger's current mode. Each of these will illuminate a different colour and will emit a sequence of flashes that indicates the charger's current state.

LEDs relating to the primary LED light:



ALL LEDs are off

The charger is not receiving power; it may be disconnected from the mains. There is no power to the front panel (The ribbon cable or its connections maybe damaged or disconnected).



Primary LED lit, white

A solid white LED indicates that the charger is set up and ready to go.



Primary LED flashing, white

The unit has successfully connected to the internet and needs to be commissioned or the unit has successfully connected to the internet, is commissioned and is carrying out cache telemetry (The time this process takes depends on internet speed and the time the charger has been offline).



Primary LED lit, blue

The charger is in boost mode (This is activated by pressing the boost button either in the app or on the front of the charger).



Primary LED flashing, blue

The charger is processing a software update.



Primary LED lit, yellow

The charger is in solar mode (This is activated on the app).



Primary LED lit, red

A serious fault has occurred (This could be an RCD-DD trip event)

- Power cycle the charger
- If it persists, contact Indra customer support.



Primary LED flashing, red

There is a temporary fault with the charger (This could be a PESTs trip)

- Unplug the vehicle.
- Wait for 10 minutes to see if the fault clears.
- Power cycle the charger
- If it persists, contact Indra customer support.



Primary LED lit, purple

The charger is booting up.



Primary LED flashing, purple

There is a problem connecting to the internet.

- Ensure all connections are soundly made
- Ensure other devices are working on the customer's router
- Ensure the Wi-Fi Dongle is successfully paired (Where applicable)
- Restart the customer's router (Where applicable)
- Refer to 4G indicator lights (Where applicable)
- If it persists, contact Indra customer support



Primary LED lit, orange

Wi-Fi pairing has been initiated.

○○○○○ LEDs relating to the four ascending panel LEDs



4 panel LEDs are off

The charger is not connected to the car.



4 panel LEDs are steady

The charger is offering a charge to the car but is “idle” (The car is not accepting a charge).



4 panel LEDs are racing downwards

The charger is charging the car (The speed the lights move at represents the rate of charge).



4 panel LEDs flashing, white

The car is plugged in but the charger is not offering charge.



Contact us

For more information, please contact us;



Email us
support@indra.co.uk



Call us:
(+44) 01684 770 631



Online support
[www.indra.co.uk/
support](http://www.indra.co.uk/support)

Indra Smart LUX™

User Guide

Be at the forefront of EV charging with
Indra's pioneering technology



Important Safety Notes



WARNING: Smart LUX™ charger installation must only be performed by a certified electrician.



WARNING: Use the Smart LUX™ only as directed.



WARNING: Do not use the Smart LUX™ if it is defective, appears broken, cracked or fails to operate or is otherwise damaged. In this case, you must report the damage immediately to your original installation partner, quoting the serial number as shown on the product label.



WARNING: Do not insert any foreign objects into the Smart LUX™ or its charging lead.



WARNING: Do not expose the Smart LUX™ or its components to open flames.



WARNING: Do not expose the Smart LUX™ to heating equipment.



WARNING: Do not immerse the Smart LUX™ or its components in water or other fluids.



WARNING: The Smart LUX™ is not to be used by persons (including children) with reduced physical, sensory or mental capabilities, or lack of experience and knowledge, unless they have been given supervision or instruction concerning use of the device by a person responsible for their safety.



WARNING: Install the Smart LUX™ in a location that mitigates damage from flooding.



WARNING: Operating or storing the Smart LUX™ in temperatures outside its specified range may cause damage to the charger.



CAUTION: Ensure that no water sources are above or near the Smart LUX™, such as taps or sprinklers.



CAUTION: Ensure that the charging lead is correctly and neatly stowed after use, to prevent any inadvertent tripping hazards.

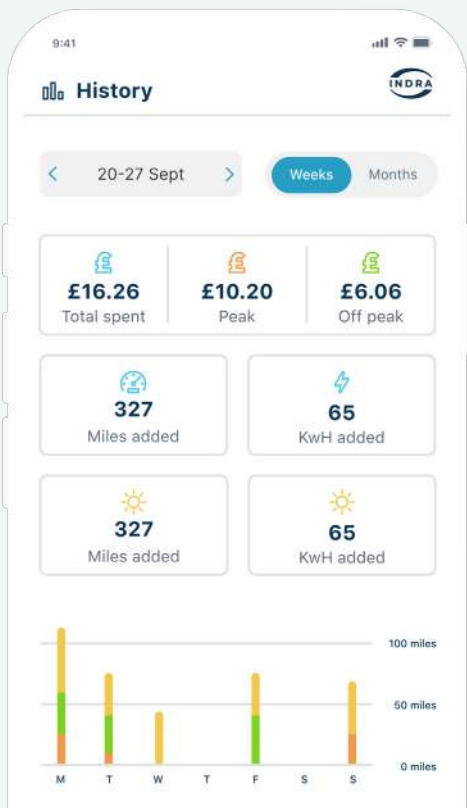
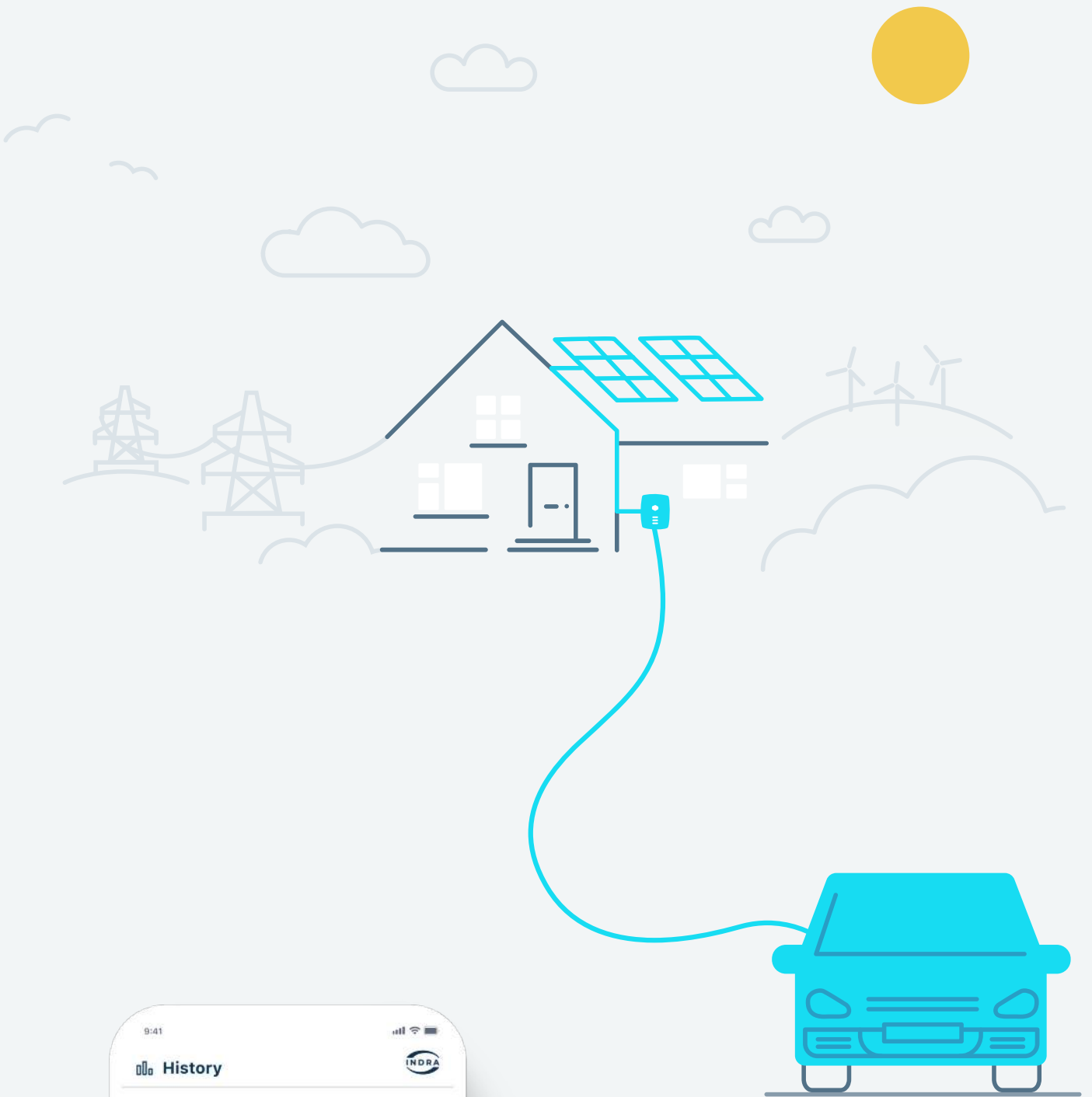

Specifications

Key features



Solar
matching



Load
limiting



Load
curtailment



Ready-by
time



Unrivalled
durability

Electrical

Rated power	7.4kW
Charging current	6A-32A variable
Protection	6mA DC leakage detection
Standby consumption	<5W

Mechanical

Dimensions	201mm x 306mm x 78mm (WxHxD)
Weight	4.0kg (with 6m charging lead)
Operating Temperature	-20°C to +50°C
Enclosure	Polycarbonate, IP67 rated
Impact Rating	IK10

Compliance

CE Marked and UKCA	✓
Standards and regulations	The Electric Vehicles (Smart Charge Points) Regulations 2021, BS EN 50581, BS EN 60529, BS EN 61010-1, BS EN 61851-1, IEC 61851-21-2, IEC 61851-22, BS 7671, BS 7671 Amendment 2, G100

Controls and Indicators



- 1 Primary Status LED**
Multi-coloured, highlighting the operational state and mode
- 2 Charging Status Ascending LEDs**
Four individual LEDs indicating whether the unit is disconnected from your EV, connected but idle or charging
- 3 Turbine Indicator LEDs**
A 'halo' of LEDs complimenting the Charging Status Ascending LEDs, providing a unique lighting sequence for each charger interaction
- 4 Tethered Charging Lead**
Your charger will come with a 6m or 10m charging lead attached
- 5 BOOST Button**
If you need to override your pre-set schedule, press BOOST on the unit or in the App to charge instantaneously at maximum rate
- 6 RFID scanner**
Tap your RFID tag in the area of this icon to activate RFID functionality within your Indra App

Welcome

Congratulations on your purchase of a Smart LUX™! The Indra team hope you'll be delighted with the features, quality and user experience of the Smart LUX™.

This guide covers how to get started with your Smart LUX™, explains key features, troubleshooting tips and important safety and warranty information.

It is important that you read this guide carefully before using the Smart LUX™, so you're completely familiar with all features and safety advice and are able to get the most from your Smart LUX™.

Overview

The Smart LUX™ is a permanently installed electric vehicle charger providing up to 32 Amps (7.4kW) at 230V, 50Hz. There are 8 Smart LUX™ variants:

- Smart LUX™, Type 2 Tethered, Symphony Black, 6m (SMNFGT2BL401)
- Smart LUX™, Type 2 Tethered, Symphony Black, 10m (SMNFGT2BL402)
- Smart LUX™, Type 2 Tethered, Indra White, 6m (SMNFGT2WH401)
- Smart LUX™, Type 2 Tethered, Indra White, 10m (SMNFGT2WH402)
- Smart LUX™, Type 2 Tethered, Elgar Grey, 6m (SMNFGT2GY402)
- Smart LUX™, Type 2 Tethered, Elgar Grey, 10m (SMNFGT2GY404)
- Smart LUX™, Type 2 Tethered, Malvern Stone, 6m (SMNFGT2GY401)
- Smart LUX™, Type 2 Tethered, Malvern Stone, 10m (SMNFGT2GY403)

The Smart LUX™ works like conventional chargers, but also offers a range of smart charging modes, designed to take advantage of local generation (e.g. solar PV), variable rate tariffs (e.g. Time of Use). In all modes, the Smart LUX™ calculates the best charging schedule that gets your EV ready when you need it.

Downloading the Indra App

Once your Smart LUX™ charger has been installed, you will need to download the Indra App from your phone's App store. Alternatively scan the QR code below and follow the instructions.



When requested please scan or enter the MAC address via the QR code located on the left hand side of the charger. Please note: in some instances it may take up to 48 hours for a newly installed charger to pair with the Indra App. Should you experience any difficulties, please contact support@indra.co.uk.

Designed to assist you in getting the most out of your Smart LUX™, the Indra App is intuitive to use and enables you to manage all the smart charging functionality of your Smart LUX™ from the palm of your hand. Creating an account takes minutes and once signed in you will be guided through the initial set-up and details of the key smart features, including:



Smart Charging

Use the Indra App to set up a recurring charging schedule. Choose regular slots throughout the week, and the charger will automatically start charging during those times, as long as your EV is plugged in of course.



Solar Power

If you have solar panels installed at home, your charger can be set up to receive power from them. The charger will take any surplus solar power that's above 1.4kW not being used by your home, to charge your EV.



Charging History

View your charging history on the app, review your usage and check if you're charging at the most efficient time.



Using Boost

Plans changed? The Smart LUX™ Boost feature lets you temporarily override your schedule to get your car fully charged as soon as possible.

Getting set up

The first time you open the Indra App, you'll be asked to set up your charger. This should only take a few minutes to complete.

We'll ask you for information about yourself, your EV and your electricity supplier and tariff. Having this information means we can calculate your charging times, electricity usage and amount spent correctly, which will enable you to optimise your smart charging. If you skip any steps in the set-up stage, you can do them later via the settings section.

You can still charge your EV without going through the set-up process, but you won't be making the most of your charger's advanced features.

Info we'll need about your EV:

- Vehicle name (the nickname you want to call it in the app)
- Number plate (we'll use this to find out more about your vehicle, such as its make and model)

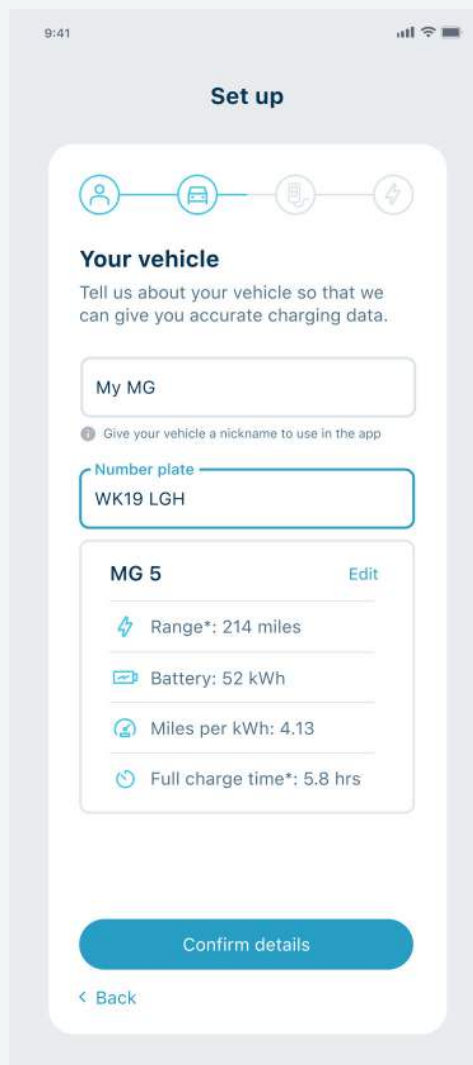
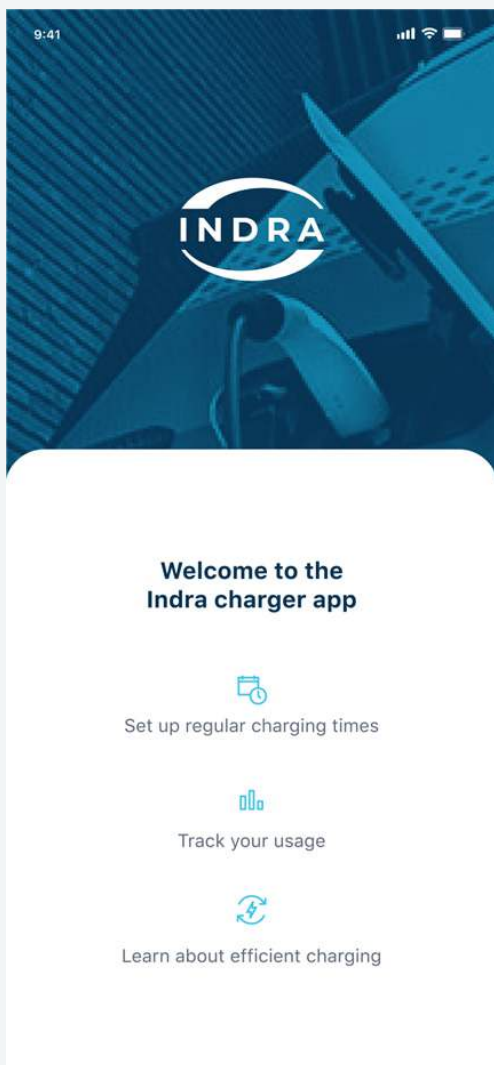

Info we'll need about your electricity supplier

Telling us about your electricity supplier and your tariff means we can help you charge at the most efficient times for you. By providing your electricity rate, we can not only calculate and show you how much you're spending, but you can also set the amount of money you want to spend on a charging session (e.g. adding £5-worth of charge to your car). We will ask you for details on:

- Who your supplier is
- Name of your tariff
- What kind of tariff you have
- What the unit (kWh) price is for your electricity
- Tariff end date (if you have one)

The screenshot shows the 'Set up' screen with a progress bar at the top. The first step, 'Who is your electricity supplier?', is active. Below the title is a link 'Why we need this information'. A grid of supplier logos is displayed: British Gas, e.on, octopusenergy, ovc, EDF, good energy, SCOTTISHPOWER, and Other. A 'Next step' button is at the bottom, along with 'Back' and 'Skip this step' options.

The screenshot shows the 'Set up' screen with a progress bar at the top. The second step, 'What is your tariff called?', is active. Below the title is explanatory text and a link 'Help with tariffs'. A dropdown menu shows 'Go Faster (4H from 0130) Jul...'. Below this is a 'Your tariff' section with an 'Edit' link, showing the provider as octopusenergy. It lists the 'Standard rate' (Unit price: 38.149p) and the 'Lower rate period' (Time: 01:30 - 05:30, Unit price: 7.142p). A 'Next step' button is at the bottom, along with 'Back' and 'Skip this step' options.

Notifications

We'd like to send you notifications about your charging status. You can choose which notifications you want to receive as well as how and when you want to receive them. This is something you have complete control over, and we promise to never send you unwanted messages.

There are three types of notification:

- Push notifications (which go direct to your phone)
- In-app notifications (which pop up while you're using the app)
- Emails

Notifications you can choose to receive include:

- Vehicle plugged in
- Charging started
- Charging finished
- Charging error
- Charger error

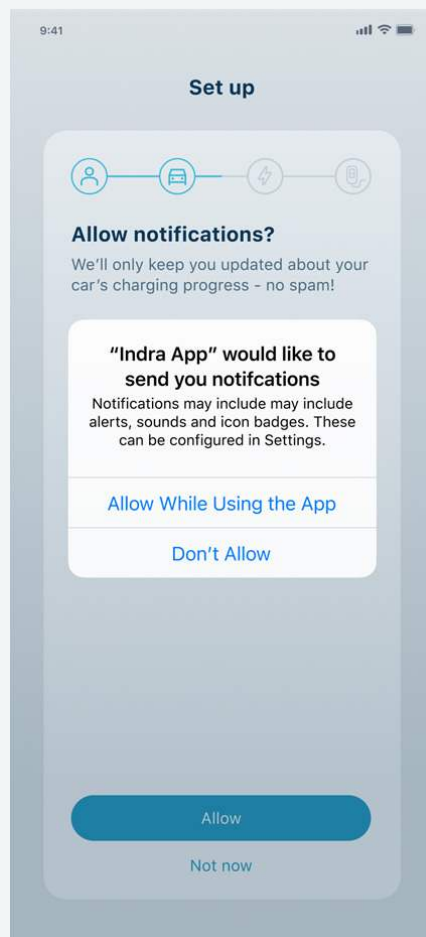

Setting up scheduling and smart charging

Use the Indra App to set up a regular charging schedule. You can choose regular slots throughout the week and the charger will automatically start charging during those times, as long as your EV is plugged in.

The app enables you to set the times and days/nights you want to charge and also how much energy to add (by miles, kWh or amount of money).

If you have more than one electricity tariff rate (e.g. peak and off-peak), you can set up smart charging to charge your vehicle as much as possible during your lower rate period.

Default schedules

Your charger will come with a default charging schedule, as required by government legislation. This schedule is designed to reduce power demand at peak times and protect the national grid. But it might not be the best charging schedule for your needs, so we recommend you set up your own schedule once your charger is installed.

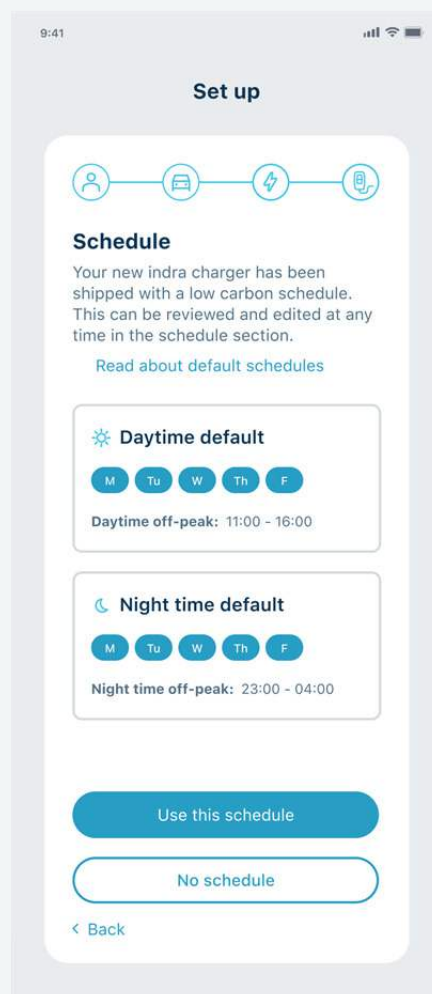

Charging lead stowage



NOTE: APPROPRIATE CHARGING LEAD STOWAGE IS ESSENTIAL TO PREVENT INADVERTANT TRIPS/ FALLS OR DAMAGE TO THE EV CONNECTOR

Tethered Variants

- We recommend that you use the charging lead hook provided with the charger when stowing your charging lead.
- Depending on the layout of your charger, you may want to fit the charging lead hook below, above or to the side of your Smart LUX™ charger.
- You can also use the top lip of the Smart LUX™ charger to wrap and store the charging lead, and it has been designed with this in mind.

Turbine lights

A unique light sequence provides a welcoming handshake and communicates the charger's status. These lights trace around the full circumference of the front panel and are visible through the turbine of the charger.

The Turbine lights can be turned off via the Indra App at any time via the settings.



What do the LEDs on my charger's front panel mean?

There are two separate LED indicators on the Smart LUX™. The Primary LED indicates the charger status, while the four panel LEDs highlight the charger's current mode. Each of these will illuminate a different colour and will emit a sequence of flashes that indicates the charger's current state.

LEDs relating to the primary LED light:



ALL LEDs are off

The Smart LUX™ is not receiving power. It may be disconnected from the mains. Check all the switches in your consumer unit are correctly set.



Primary LED lit, white

A solid white LED indicates that the Smart LUX™ is set up and ready to go. The charger is now in smart mode and will charge based on the schedule set up in the Indra App.



Primary LED flashing, white

The Smart LUX™ has successfully connected to the Internet and is almost ready to start charging. If the unit has been switched off for a long period without being connected to the Internet, then this process may take some time, please contact Indra Customer Support for a more accurate timeframe.



Primary LED lit, blue

The Smart LUX™ is in Boost mode, which is activated using your Indra App or by pressing the Boost button on the charger.



Primary LED lit, yellow

The Smart LUX™ is in Solar mode and is accessing energy generated from solar panels to charge the EV. You can set this up under 'Electricity Supplier' in your Settings menu within your Indra App. When selected, the charger will automatically use energy from your solar panels when it's available.



Primary LED flashing, blue

The Smart LUX™ is processing a software update. Ensure the charger is online and that no charging is taking place during this process.



Primary LED solid or flashing, red

Flashing – The charger has identified a potential fault in the supply network and has stopped charging for safety reasons. If this state endures, power cycle the charger by turning it off at the consumer unit then back on after a few minutes. If the charger continues to flash red then call Indra Customer Support on (+44) 01684 770 631.

Solid Red – the charger has detected an error. Power cycle the charger by turning it off at the consumer unit then back on after a few minutes. If the RED light continues to display the call Indra Customer Support on (+44) 01684 770 631.



Primary LED flashing, purple

A flashing purple light on the Smart LUX™ indicates that it has lost communication with the Internet or the Indra App.



○○○○○ Charging Status Ascending LEDs:



4 panel LEDs are off

If the four panel LEDs below the primary LED are off, then the Smart LUX™ is not connected to the EV.



4 panel LEDs are lit

With the four panel LEDs illuminated, the Smart LUX™ is connected to the EV and is currently in 'idle' mode, waiting to charge.



4 panel LEDs are racing downwards

The Smart LUX™ is in charging mode and your EV is currently being charged.



Green when a charge is scheduled

The Smart LUX™ is not currently charging, but the EV is connected and a charging session has been scheduled.



Flashing Green - Fixed Load Calibration

The installation engineer has triggered the Fixed Calibration Load function as part of the charger's set-up process. This will only be seen by the installer during installation.



4 panel LEDs flashing, white

The vehicle is no longer accepting charge. It is likely that the battery is fully charged.



Leave us a Trustpilot review:



Contact us

For more information, please contact us;



Email us
support@indra.co.uk



Call us:
(+44) 01684 770 631



Online support
[www.indra.co.uk/
support](http://www.indra.co.uk/support)