

Recharge

Installation Guide

TWENTY
TWO
DUAL

INSTALLATION GUIDE V1.0

Introduction.

This manual, and the functions described in it, are valid for the installation of VCHRGD Technologies, tethered and socketed, dual 22kW AC chargers.

This manual is designed exclusively for trained, qualified personnel. These are people who, due to their training, skills and experience, and knowledge of the relevant standards, can assess the work assigned to them and identify possible dangers.

The illustrations and explanations contained in this manual refer to a typical version of the device.

Your device version will vary in performance, functionality and connectivity dependent on the version ordered according to the orderable manufacturer part numbers listed below.













Please refer to the manual for information and instructions for operating the device.

Orderable Part Number	Product Description Including Variable Features
E022-SUH-LW-01	VCHRGD TwentyTwo Dual Untethered Type 2 Unit RJ485 + WiFi
E022-STH-LW-01	VCHRGD TwentyTwo Dual Tethered 5M Type 2 Unit RJ485 + WiFi
E022-SUH-LG-01	VCHRGD TwentyTwo Dual Untethered Type 2 Unit - 4G Module (Data Package Sold Separately)
E022-STH-LG-01	VCHRGD TwentyTwo Dual Tethered 5M Type 2 Unit - 4G Module (Data Package Sold Separately)
E022-SUH-WG-01	VCHRGD TwentyTwo Dual Untethered Type 2 Unit - WiFi + 4G Module (Data Package Sold Separately)
E022-STH-WG-01	VCHRGD TwentyTwo Dual Tethered 5M Type 2 Unit - WiFi + 4G Module (Data Package Sold Separately)

Power Rating per socket ie. 22KW	Connector T - Tethered U - Untethered	Connectivity W – WiFi 2.4GHz L – LAN/RJ485 G – 4G (GSM)	Special Designator 01 – Standard Variant
E022	- S(U/T)H	- W/L/G	- 0x



Introduction.

-  Do not leave flammable or explosive substances near the EV Charging point; otherwise, hazardous blast may result.
-  Installation and wiring should be done by professionally qualified persons, otherwise there is a risk of electric shock.
-  Make sure input power supply is entirely disconnected before wiring, otherwise there is a risk of electric shock.
-  The Earth terminal of the EV Charging point must be grounded securely. Failure to do so may result in the risk of electric shock.
-  The lead nose of the charging point must be securely attached or there is a risk of damaging the equipment.
-  Leave no metals such as bolts, gaskets into the inside of the EV Charging point.
-  It is strictly forbidden for minors or persons of restricted capacity to approach or operate the charging point .
-  Forced charging is strictly forbidden in the event of the electric vehicle or charging point fails
-  It is strictly prohibited to use the charging point when the charging adapter or charging cables are defective cracked, worn, broken or if the charging cables is exposed. If you find any, please contact the supplier immediately.
-  The EV can only be charged with the engine off and stationary.
-  Accessory replacement must be done by qualified personnel, thrums or metals are prohibited to be left in the charger.
-  It is recommended that routine safety inspection visits to charging point be conducted in line with BS7671 wiring standards
-  Keep the charging connector clean and dry and wipe with a clean, dry cloth if soiled.

















Introduction.

Product Appearance.



Other Features.

 <p>Dynamic Output</p> <p>Configurable outputs of 2x22kW, 2x11kW for 3-phase inputs and 7.4kW split for 1-phase</p>	 <p>Load Balancing</p> <p>Hard wired dynamic load balancing with CT's provided in box. Wireless solutions in development</p>	 <p>Robust Casing</p> <p>Robust and corrosion resistant aluminium casing. Chargers built to last in any environment</p>	 <p>RFID</p> <p>Built-in RFID reader for easy charge card registration and local charge authorisation</p>	 <p>MID Metering</p> <p>2x MID metered channels to ensure the highest level of metering compliance for billing</p>
 <p>Easy Installation</p> <p>Hinged front door and clearly laid out internal wiring termination for a quick & easy install</p>	 <p>OCPP 1.6</p> <p>OCPP 1.6 compliant for easy integration with plethora back-end service providers</p>	 <p>Universal Socket</p> <p>2x Universal Type 2 sockets, high quality connectors with built in flanges for debris & water</p>	 <p>Secure</p> <p>Compliant with all UK smart charging standards & encrypted bluetooth, WiFi & 4G comms</p>	 <p>PEN Protection</p> <p>Simplified installation and reduced project costs, through built in OPEN protection</p>
 <p>Compact</p> <p>Densely packed with features all in one for the industries smallest form factors at 465 x 254 x 135mm</p>	 <p>Protection</p> <p>PEN Fault, RCM, OV/UV, Over Current, Short Circuit, Over Temperature & Type A + 6mA RCD</p>	 <p>Anti-Tamper</p> <p>Magnetic anti-tamper switch built in for case open detection and emergency cut-off</p>	 <p>Touch Screen</p> <p>4.3" TFT Touch Screen for on site configuration, customisation and charging information</p>	 <p>Connected</p> <p>Configurable connectivity with WiFi, 4G and Ethernet. Your connection, your choice</p>

Introduction.

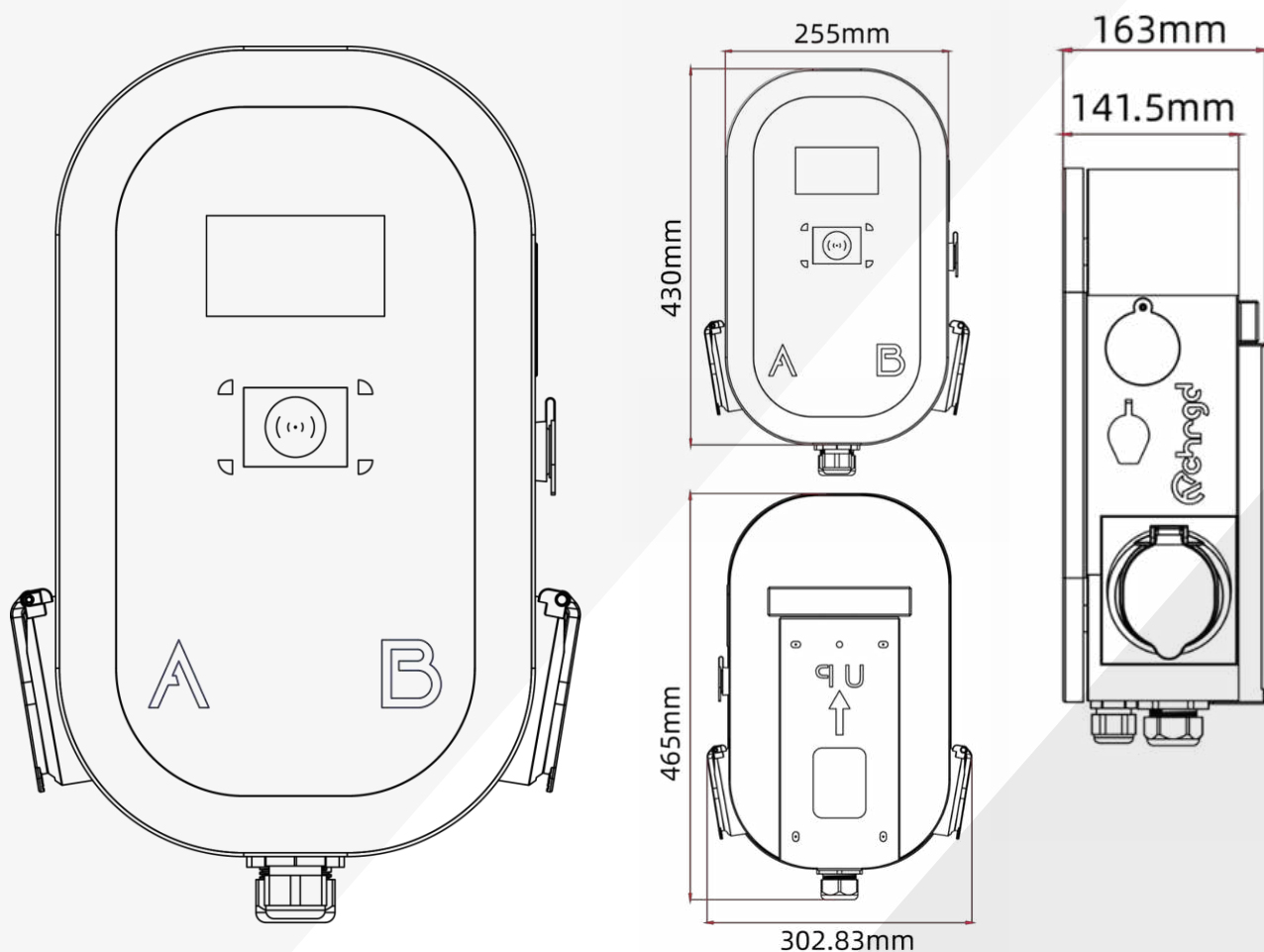

Output Current Setting	Maximum Charging Rate (kW)	
	Single Connector in Use	Both Connectors in Use
64A (3 phase supply)	1 x 22 kW	2 x 22kW
32A (3 phase supply)	1 x 22 kW	2 x 11kW
32A (3 phase supply)	1 x 7kW*	2 x 7kW*
32A (1 phase supply L1)	1 x 7kW	2 x 3.5 kW

Please Note

The TwentyTwo Dual is designed to handle a total output capacity of 44kW at 64A on an incoming 3 phase supply. The denoted output settings above are achieved and optimised by limiting the incoming power supply, and then configuring the charge point max output current via the password protected touch screen LCD menu. For all configurations lower than 2 x 22kW the output current must be reduced to 32A from 64A to ensure correct connector power balancing is implemented.

**Can be limited to 2x 7kW via dedicated FW update if required*

Installation.

Specifications.

Product Details	E022 - S(U/T)H - WL/WG/LG - 01
Dimensions (mm)	465(h) x 255(w) x 163(d)
Weight (kg)	Untethered 11 kg / Tethered 13 kg
Display	4.3" LCD, 480p x 272p resolution Capacitive Touch Screen
Casing	Material 5052 aluminium Powder coat finish
Input	
Power Input	1P + N + PE (7kW) 3P + N + PE (44kW)
Rated Max Power	1P 7kW per outlet 3P 22kW per outlet (44kW total)
Rated Voltage	1P AC 230V, 50Hz 3P AC 400V, 50Hz
Max Current	32A / 64A
Standby Power	<8W
Output	
Nominal Voltage	1P AC 230V 3P AC 400V (note the OPEN range is set to $\pm 10\%$ of nominal input voltage)
Current per Outlet	1P 6A - 16A 3P 6A - 32A
IP Protection Degree	
	IP65 (Socket IP54)
Operating temperature range	-30°C~50°C
Storage temperature range	-40°C~75°C
Operational altitude	< 2000m
Relative humidity	95%RH no water droplet condensation
Vibration	0.5G, avoid acute vibration and impaction
Communication	
Wireless Communications	WiFi 2.4GHz / Ethernet 802.3 / 4G / BlueTooth™ 2.4GHz
HMI / Payment Interfaces	RFID, Mobile App (OCPP 1.6J), Contactless Payment via OCPP RGB LED Status Indication
Protection	
Leakage Protection / RCD	DC6mA (external Type A RCBO is required for AC 30mA protection on each installation)
Additional Protection	Over Current, Over Voltage, Under Voltage, Over Temperature (with load-decrease), PEN Fault Detection
Certification Standard / Body	CE / TUV SUD
Certification Standards	IEC 62955:2018, IEC 61851-1:2017, IEC 61851-21-2 IEC 62196-2

Introduction.

Specifications.

Non-Smart Functionality	RFID Plug & Go	Robust Aluminium Casing
		Dynamic Load Management
		MID Class Metered Output
		Connector Load Balancing
		LED Status Indication
Smart Functionality	App Control	WiFi / Bluetooth / 4G
		Load Monitoring
		Multi-Charger Management
		Authorised Remote Transaction requests
		Start/Stop Charge, Charging Records
		Smart Charging/ Charge Scheduling
		Off-Peak Charging
		RFID Registration / Payment Terminal Integration (OCPP 1.6J)
		OCPP 1.6J

For more detailed specifications please see the VCHRGD TwentyTwo Dual Datasheet.

You can also access all documents pertaining to EVSCP Compliance as an approved installer, either by request, through www.VCHRGD.com or they will have been sent to you on purchase of the VCHRGD TwentyTwo Dual.

End users can access the Statement of Compliance and Technical File via the VCHRGD Home app main menu.



Introduction.

Packaging.

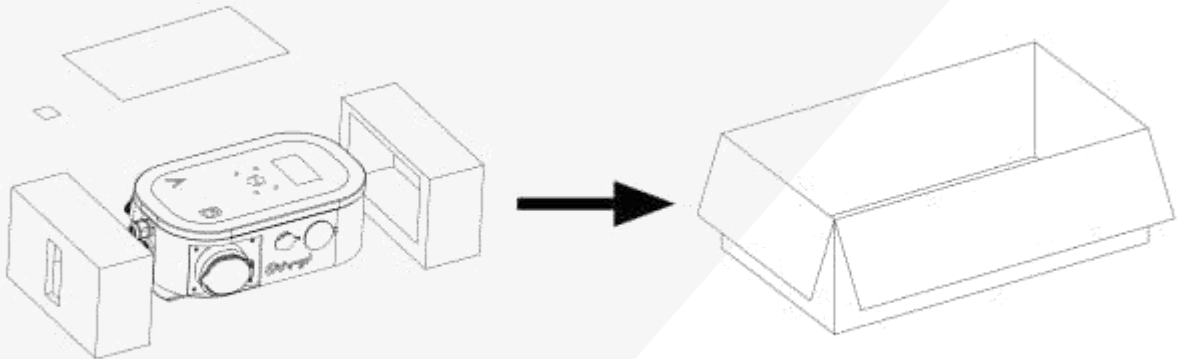

VCHRGD TwentyTwo Dual Packaging is 100% recyclable. After your installation is complete, please retain all relevant printed collateral and documentation and recycle the remaining packaging responsibly, and in accordance with your local recycling guidelines and practices.

Install Kit.

The following are provided with every purchase:

- 1x Drilling template
- 5x Insulated ferrules
- 4x 8mm \varnothing expansion wall plugs 45 to 60mm
- 4x 5mm \varnothing 45mm screws
- 1x Security Key



Installation.

Introduction.

a) This electrical device should be installed, operated, serviced, and maintained only by qualified personnel. No responsibility is assumed by the manufacturer for any consequences arising out of the use of this device. A qualified person is one who has skills and knowledge related to the construction, installation and operation of electrical device and who has received safety training to recognise and avoid the hazards involved.

b) All applicable local, regional, and national regulations must be respected when installing, repairing, and maintaining this device.



SDS or appropriate power drill
& Suitable Masonry Drill Bit.



Appropriate test equipment
(EV test adapter may be required).



Crimping tools for
incoming power line & CT connections.



Suitable mobile device for back-end
commissioning & app setup

An additional small flat head screwdriver will be required for loosening and tightening the incoming power line terminals. The charger is secured to the mounting bracket using 2x Torx+ Security Screws, the drill bit for which is provided in the fixings pack with every TwentyTwo Dual purchase.



Installation.

Protection.

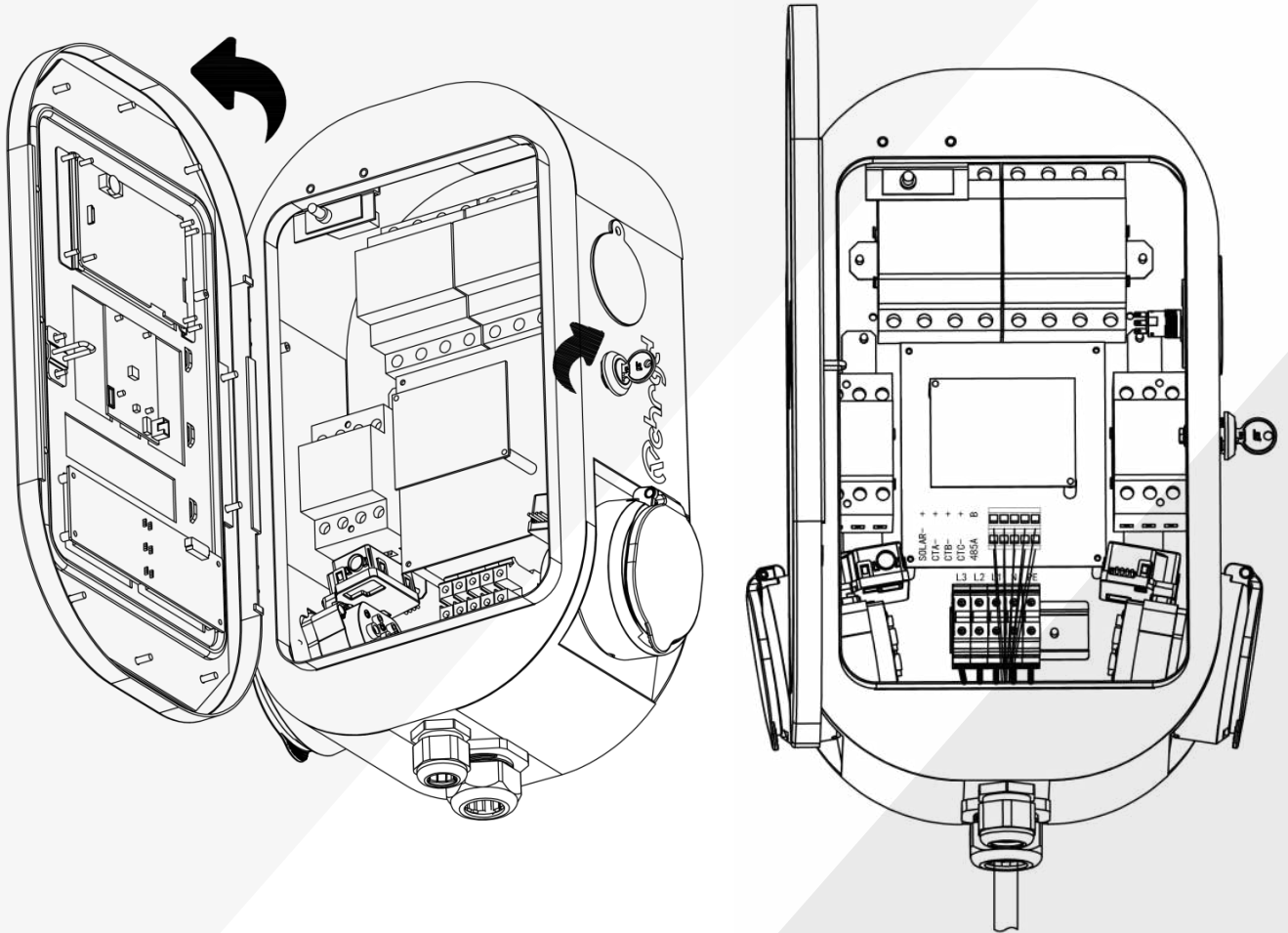

Safety precautions for installation:

The charger has integral RCD protection rated at (AC 30mA & DC 6mA). 6mA DC fault current disconnection device was verified to IEC 62955 standard by TUV SUD.

It is necessary to install a **40A or 80A RCBO** and **RCD Type A** in line before the charger, for multi-level safety protection

RCD Type A should be tested in accordance with BS 7671

Since 27TH SEPTEMBER 2022, THE NEW 18TH EDITION AMENDMENT 2 OF THE WIRING REGULATIONS CAME INTO EFFECT. WITH THESE NEW REGULATIONS, ALL NEW ELECTRICAL CIRCUITS MUST HAVE SURGE PROTECTION DEVICES (SPDS) FITTED. SOME INSTALLERS MAY CHOOSE TO ENTER INTO AN OPT OUT AGREEMENT WITH THE CUSTOMER, HOWEVER THIS IS THE SOLE RESPONSIBILITY OF THE INSTALLER TO AGREE WITH THE END USER PRIOR TO INSTALLATION.



Installation.

Bracket Mounting.

1 Identify mounting point at a height of 0.5m to 1.5m above the ground, hold bracket flush to surface, and level. Mark wall at fixing points highlighted below

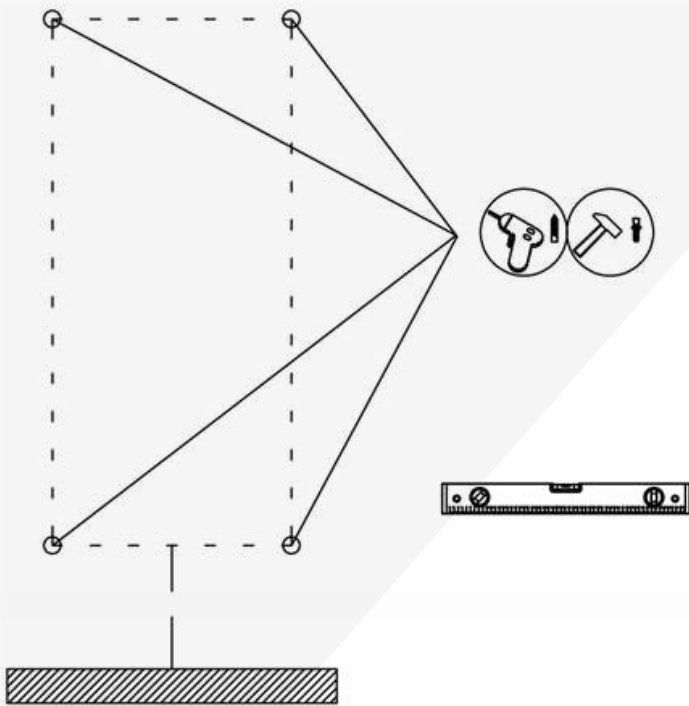

2 Drill holes accordingly M5*45mm screws provided with unit using a torque setting of 1Nm fix back plate

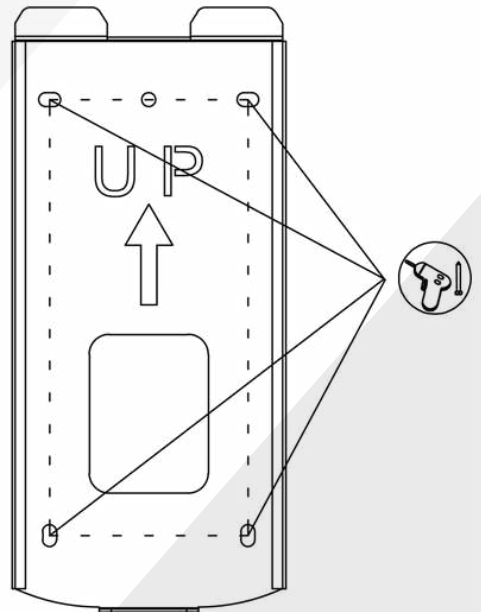

3 Slot the charging case downwards into the back plate, ensuring a secure fit and tighten with Torx+ Screws provided until secure

NOTE

As the power line is fed into the charger from the bottom of the case, please leave sufficient clearance from the mounting point to the desired termination point for the cable run.

The hinged front cover allows for easy access to the internal wiring terminals, allowing for simple termination post bracket mounting.

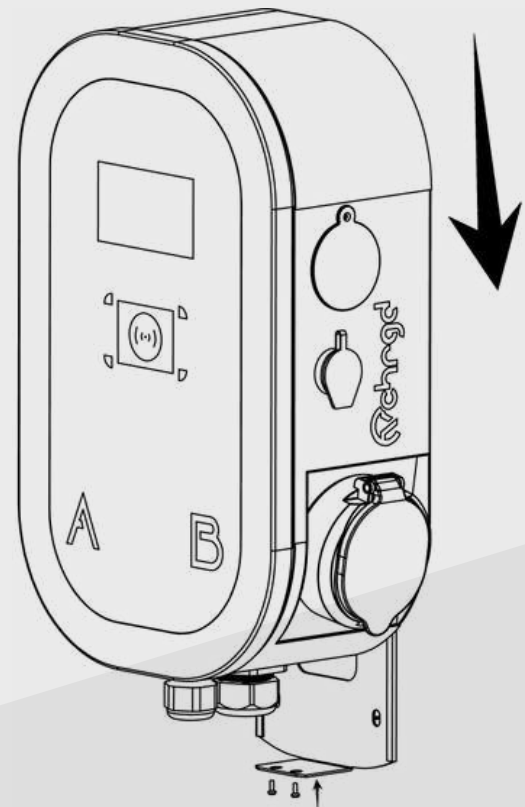

Installation.

Wiring.

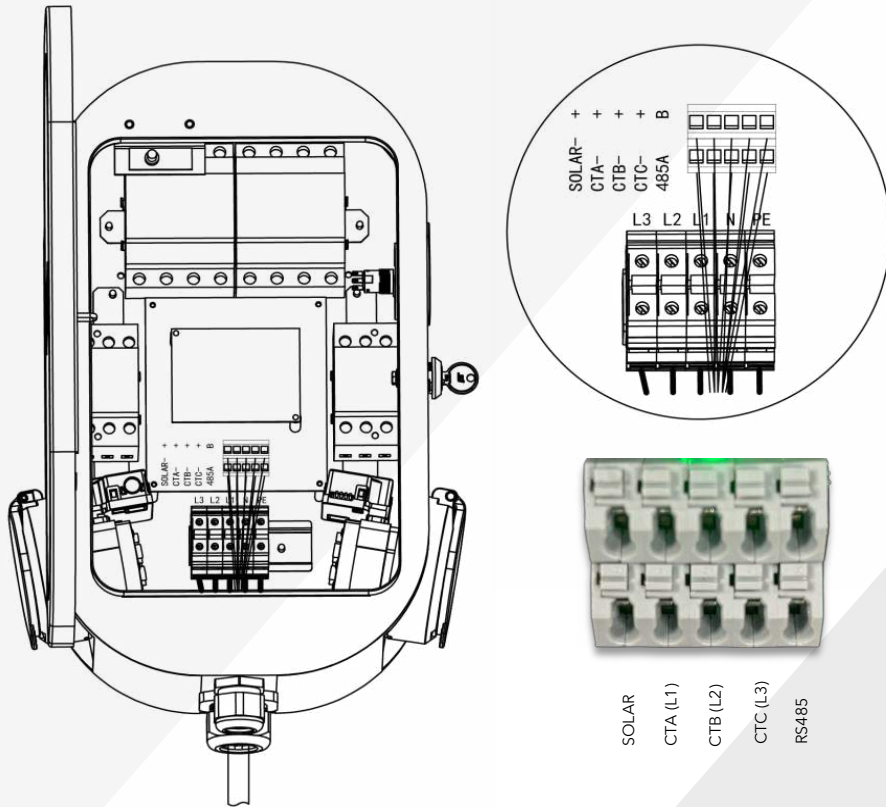

Incoming Power Line

Case internals are labelled accordingly

L1 - Live Phase 1

L1 - Live Phase 1

L1 - Live Phase 1

N - Neutral

PE - Protective Earth

Energy Management Line

From left to right the following apply.
With the top input being the positive input and bottom input being the corresponding negative

Top Row

Solar +, CT_A+, CT_B+, CT_C+, RS485_B

Bottom Row

Solar -, CT_A-, CT_B-, CT_C- RS485_A

Depress the connector release button to open the terminal and release with data line in place to secure connection

NOTE

If extending the CT clamp for dynamic load management and solar functions, please use a twisted pair connection such as CAT5E or a suitable EV cable. Match the polarity of the CT accordingly, ensuring that the coloured and white connections of the twisted pair correspond to the positive and negative inputs of the charge point side connections. A reversal of polarity will lead to inaccurate or inverse current readings.



Installation.

Dynamic Load Management

Load balancing requires the use of the specified CTs (ensure CTs are specified as required at time of order). 3 phase load balancing requires 3 x CTs per charger.

Note CT clamps are directionally sensitive, please ensure polarity matches per previous section

The maximum site/property current can be set at the installation stage via the LCD configuration menu in the **DYNAMIC LOAD** section.

On commencing a charging session, the charger will commence at 6A and increase until the monitored current reaches its maximum set value less 2A.

Should the monitored mains current change during a charging session the charger will adjust (increase or decrease) its own current to ensure the household current remains at 2A less than the maximum threshold.

Example Dynamic load threshold set to 60A >> Monitored Load = 40A

Charging commences at 6A and incrementally increases to 18A (total load 58A)

Monitored load at site decreases to 50A due to decreased mains utilisation

Outlet current increases to 26A (total load 58A) maintaining threshold buffer of 2A

Metering Interface

The charger has two-meter interfaces (MID meters) with RS485 communication and baud rate of 9600. The designated value of connector A is 1 and the designated value of connector B is 2.

To check the digit select "NONE"

The first MID meter communication is used for internal power measurement.

The second MID meter is used for external current monitoring and can be used for dynamic load balancing in place of the CT connections.



Connect.

The VCHRGD TwentyTwo Dual is designed to be a flexible and configurable enabler for multiple back-end providers and management services to connect with via OCPP 1.6J.

Using the 4.3 inch LCD touch screen the installer can commission and connect the charger to the desired back-end service via OCPP URL, connect to WiFi or 4G services, configure dynamic load management services and much more.

This section offers a complete guide to commissioning, connecting and configuring your new VCHRGD TwentyTwo Dual, the final step on the road to world class fast charging.



Connect.

Loading Screen

Displayed on first power on, this screen can be adapted to align with customer branding or CPO instructions.



Installer Menu

Configuration screen used to connect commission & configure the charger. Following simple on-screen instructions for set-up.

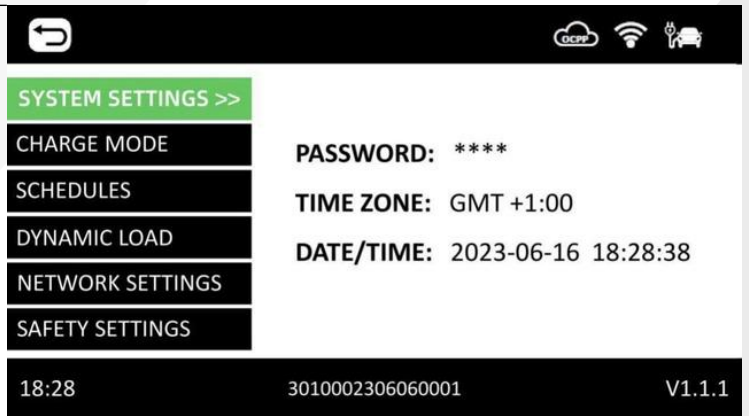

Main Screen

See the status of your two charging outlets and session information, simply select your outlet to see more detailed info.

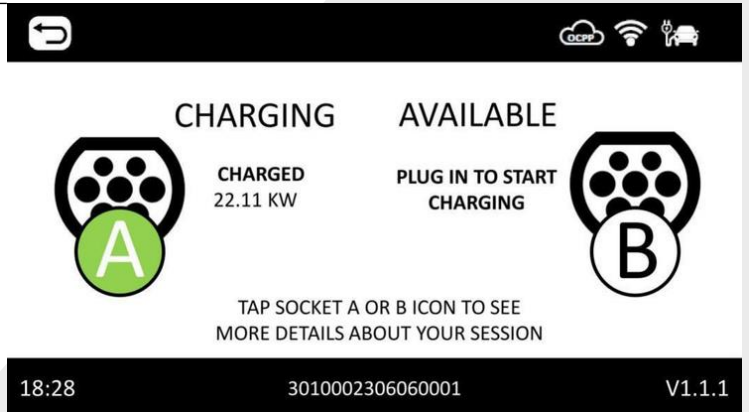

Charging Information

Providing detailed session information, outlet status, faults and error correction actions in clear written English. Empowering customers with information.

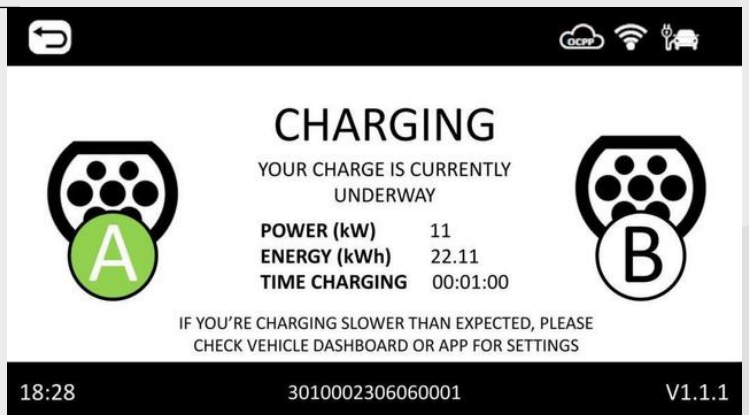

After Sales.

Fault Indication.

LED Status	Status Description	Description
All lights off / No LED status	Power down	Check L1/L2/L3/N/PE wiring
Blue light, solid	Power on standby	Normal
Green light, pulsing	Car connected, charging	Normal
Green light, flashing	Car connected, charging suspended	Normal
Green light, solid	Charging finished	Normal
LED Status Red		
Periodic constant flashing	RCM Leakage fault.	RCM self-test failed or the RCM detected a leakage or PE current greater than 25mA for more than 80ms
Flashing, 2 times	Overcurrent fault	The charging current exceeds +10% of the rated current and is greater than the rated current by 2A for more than 2 seconds. Or the charging current in the tethered version exceeds +10% of the rated current of for more than 2 seconds. Or the charging current exceeds +10% of the DLB or Smart charging limit current and is greater than the rated current by 2A for more than 12 seconds.
Flashing, 3 times	Earth fault	The voltage between N and PE is greater than 20V _{AC} for more than 3s
Flashing, 4 times	Overvoltage / Undervoltage	The incoming voltage exceeds the OV threshold for more than 3 seconds Or the incoming voltage is lower than the UV threshold for more than 3 seconds.
Flashing, 5 times	Contactors Fault	If contactor in closed state, the contactor feedback closure signal is unread for more than 3 seconds. If contactor in open state, the contactor feedback closure signal is read for more than 3 seconds
Flashing, 6 times	Control Pilot Abnormal	The CP voltage has changed from 6V to 12V or the CP voltage is not between 0~13.5V
Flashing, 7 times	Electronic Lock Failure	The electronic lock cannot be locked or unlocked. Untethered version only.
Flashing, 8 times	Over Temperature Fault	The internal NTC temperature sensor reading exceeds 100°C for longer than 5 seconds
Flashing, 9 times	Emergency Stop Pressed	In versions with an emergency stop button, it is pressed in.
Flashing, 10 times	Tamper Detection	The charger front case is open and tamper detection has been activated
Flashing, 11 times	Meter Connection Fault	Meter communication failure MID meter communication is not available
Flashing, 12 times	CP Diode Fault	The diode on the Control Pilot line could not be detected
Flashing, 13 times	Dynamic Load Management Fault	Dynamic Load Management communication failure
Flashing, fast and constant	Firmware Notification	Firmware Updating
Solid red light	Other Fault	Charger failure or firmware upload incomplete

After Sales.

Maintenance

To ensure the long term stability of the charger operation the charger and all requisite protective switchgear should be subject to regular maintenance and checks in accordance with British Wiring Standards BS7671.

Note, only professionally qualified engineering personal shall be allowed to maintain and access the internal componentry of the charger otherwise liability & warranty may be invalidated. Also, maintenance by non qualified persons may lead to charger and associated property damage plus a safety risk to the individual, for which VCHRGD Technologies Ltd. Accept no liability and are indemnified against any subsequent claim.

Checks should include, but not be limited to; operation and confirmation of the protection systems, ensuring the equipment is correctly earthed, safe and compliant with all requisite wiring standards, ensuring the charger environment remains suitable (no temperature, corrosion, inflammable, explosive risks in the area of the charger) and all terminals (including the input power connections) are suitably tightened, maintain good contact and are without any signs of abnormality or corrosion.

Office Hours

Monday to Friday, 8:30 - 17:00PM
(except national and public holidays)

Contact Information

Telephone: +44 1494 370523

Email: info@vchrgd.co.uk

Website: <https://vchrgd.com>

Address:

Unit 1a Eghams Court,

Bourne End,

High Wycombe,

SL8 5YS, UK



After Sales.

Warranty.

The charger is guaranteed for 3 years and the warranty cover is active within 3 years of installation.

For issues caused by the charger itself, including faulty operation or limited functionality. On-site assistance, repair and replacement will be provided free of charge to the end user.

The warranty for problems caused by the charger itself, or derived from faulty product covers; spare parts and VCHRGD Seven replacement, as well as the corresponding maintenance & labour costs;

Damage inflicted to the charger or property as a result of accidental damage, natural disasters, misuse, or improper installation is not covered by the warranty.

For warranty, claims, please contact the VCHRGD Sales Support Team and describe the cause of the problem in detail. It is best to provide a photo or video with your warranty claim, so that our service staff can quickly locate the cause of the problem, and work to find a resolution.

Sales Support Line 01494 370525

Sales Support Email sales@vchrgd.com

